



Dima
Radiator

www.dimaradiator.com

radiatorsteel_dima



☎ ۰۲۴-۳۳۷۸۴۱۹۰

☎ ۰۹۱۹ ۸۴۲ ۶۷۹۷

📷 KARNOSANAT

📍 @Karnosanat1

🌐 www.karnosanat.ir

📍 زنجان، بالاتر از میدان ولیعصر

نیش درب پرسنلی بیمارستان ولیعصر

Collection 2024

DIMA Radiator

DIMA RADIATOR

COLLECTION
2024 + FRAAI
MOOR

5

NEW

model collection
Of Dima Radiator



Model: D
Stainless steel DIMA Radiator

New

Model	Width[w]	Height(H)	No.of Blade	Output Heat		Connections
				Watts	KCal	
D0801	80	1800	1	792	681	50-84



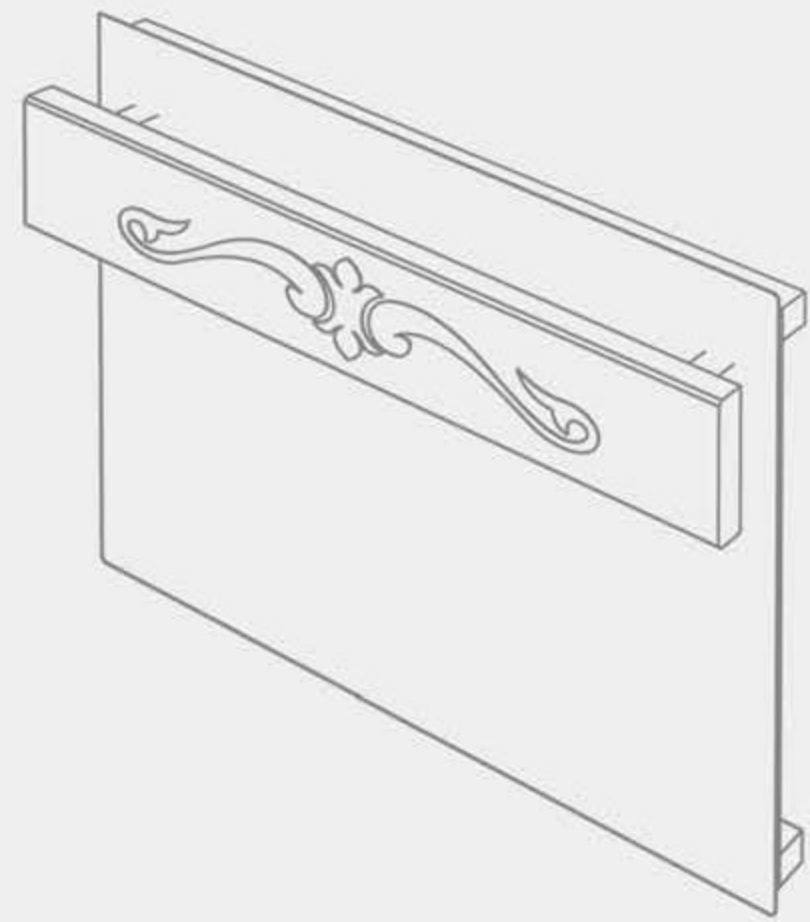

Model: **HF**
Stainless steel DIMA Radiator

New

Model	Width[w]	Height(H)	No.of Blade	Output Heat		Connections
				Watts	KCal	
HF6610	660	460	10	650	561	500



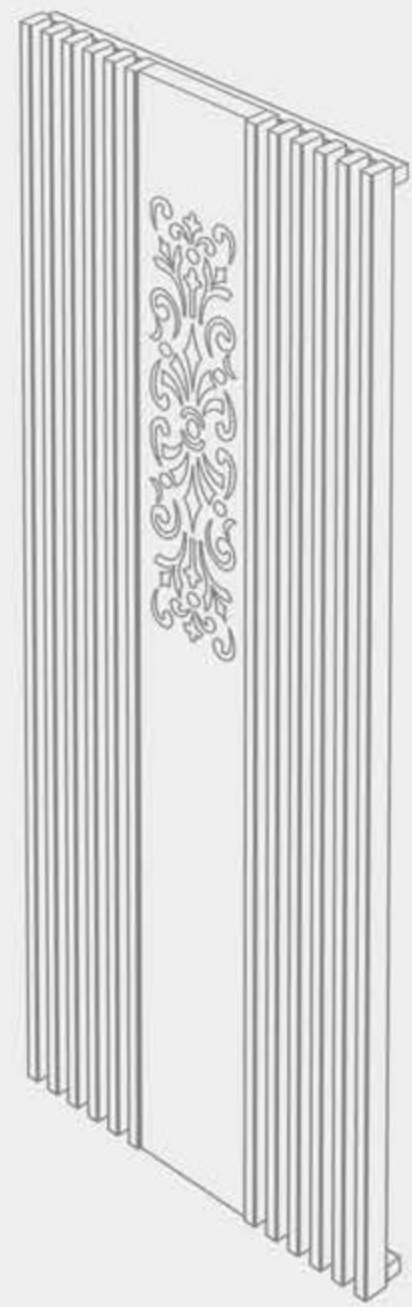

Model: 2P
Stainless steel DIMA Radiator

New

Model	Width[w]	Height(H)	No.of Blade	Output Heat		Connections
				Watts	KCal	
2P6512	650	1800	12	2376	2044	730

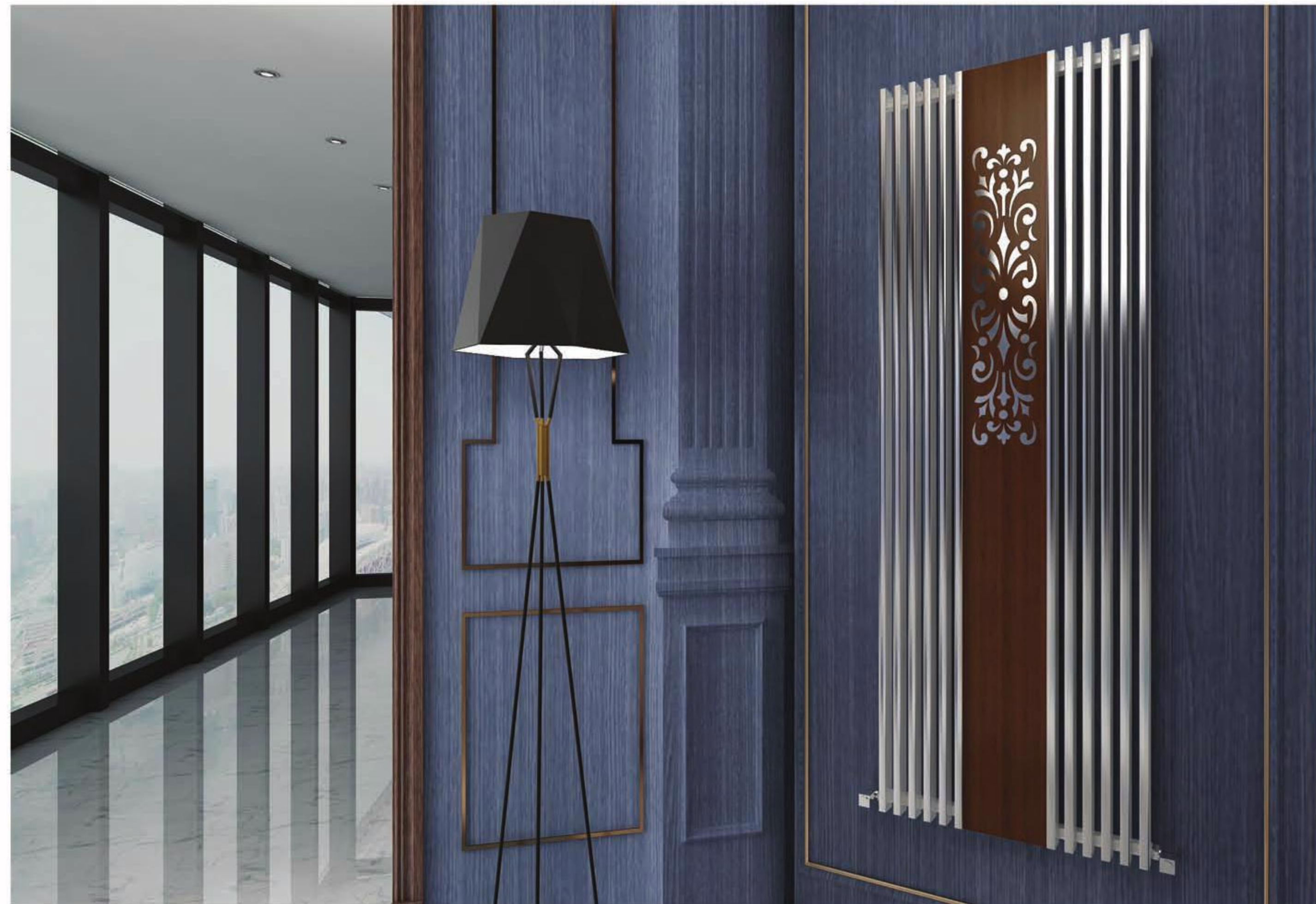

Model: FC
Stainless steel DIMA Radiator

New

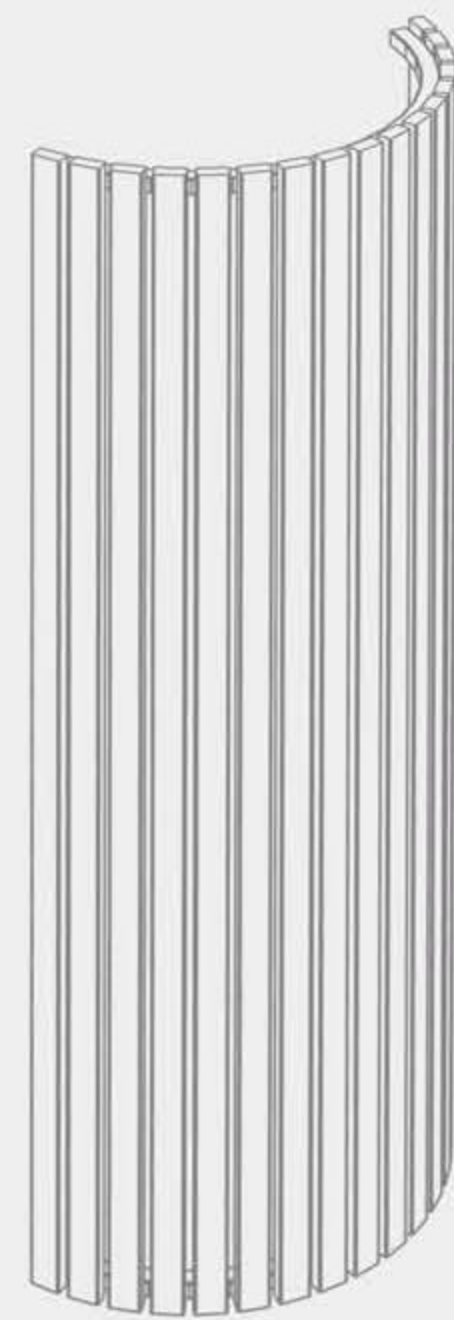

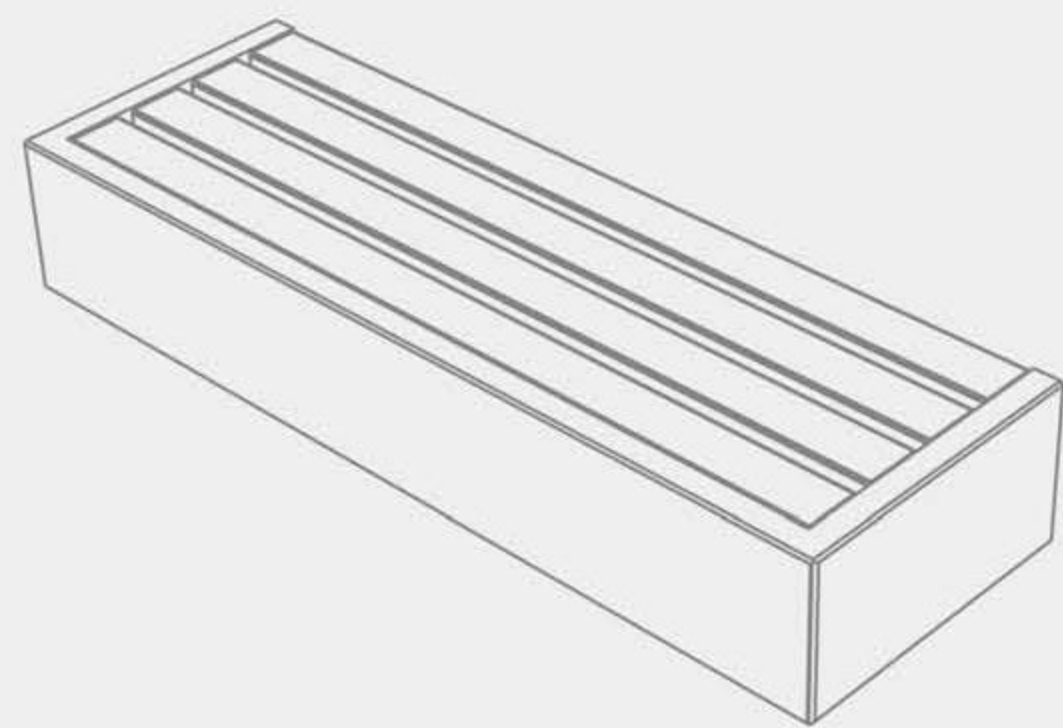

Model: K
Stainless steel DIMA Radiator

New

Model	Width[w]	Height(H)	No.of Blade	Output Heat		Connections
				Watts	KCal	
K2104	210	720	4	278	240	500



DIMA
RADIATOR

Just Choose
THE BEST

Model: A

Stainless steel DIMA Radiator

Model	Width[w]	Height(H)	No.of Blade	Output Heat			Connections
				Watts	KCal	KCal+	
A4110	410	1800	10	1584	1363	1635	490
A4912	490	1800	12	1900	1635	1962	570
A6115	610	1800	15	2970	2044	2452	690
A8120	810	1800	20	3168	2750	3300	890



Model: A black

Stainless steel DIMA Radiator

Model	Width[w]	Height(H)	No.of Blade	Output Heat			Connections
				Watts	KCal	KCal+	
A4110	410	1800	10	1584	1363	1635	490
A4912	490	1800	12	1900	1635	1962	570
A6115	610	1800	15	2970	2044	2452	690
A8120	810	1800	20	3168	2750	3300	890



Model: **AT**

Stainless steel DIMA Radiator

Model	Width[w]	Height(H)	No.of Blade	Output Heat		Connections
				Watts	KCal	
AT3609	360	1800	9	1386	1192	440
AT5213	520	1800	13	1980	1704	600
AT6817	680	1800	17	2574	2215	760

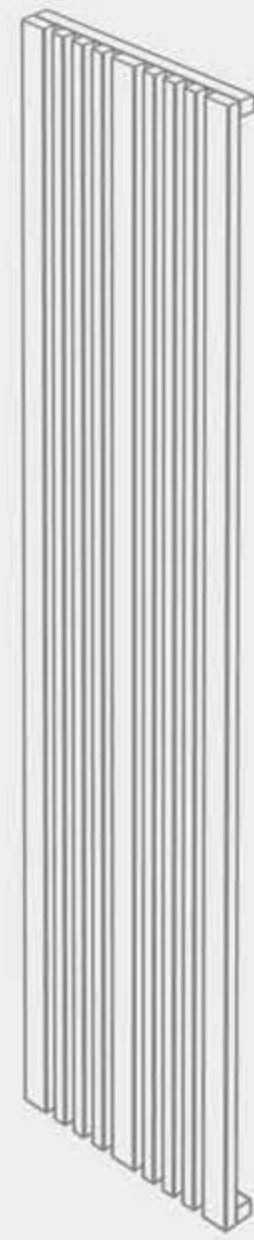

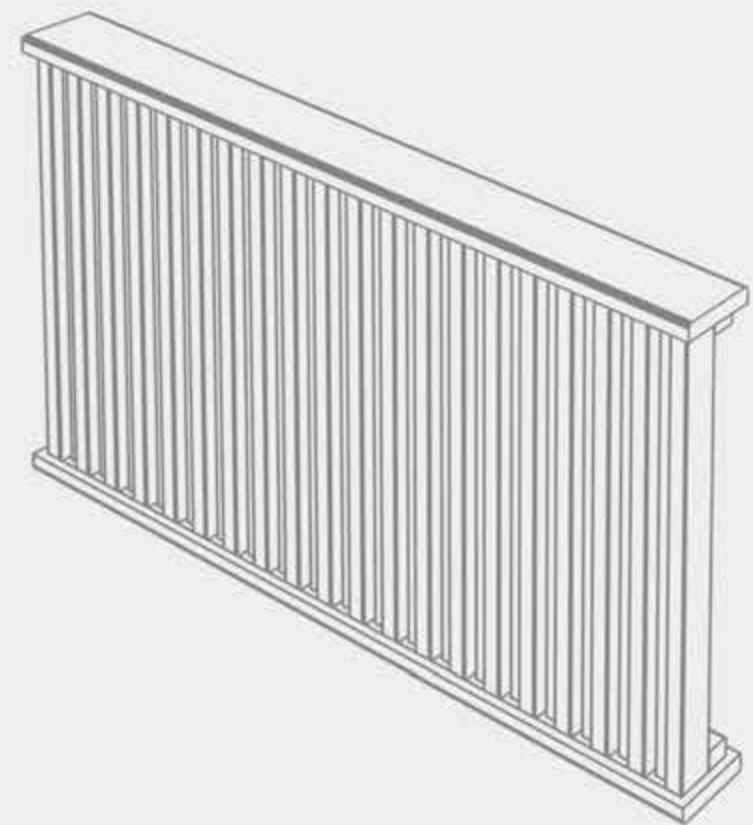

Model: B

Stainless steel DIMA Radiator

Model	Width[w]	Height(H)	No.of Blade	Output Heat		Connections
				Watts	KCal	
B6529	650	525	29	1520	1320	500
B8739	875	525	39	2048	1780	500
B11049	1100	525	49	2570	2230	500



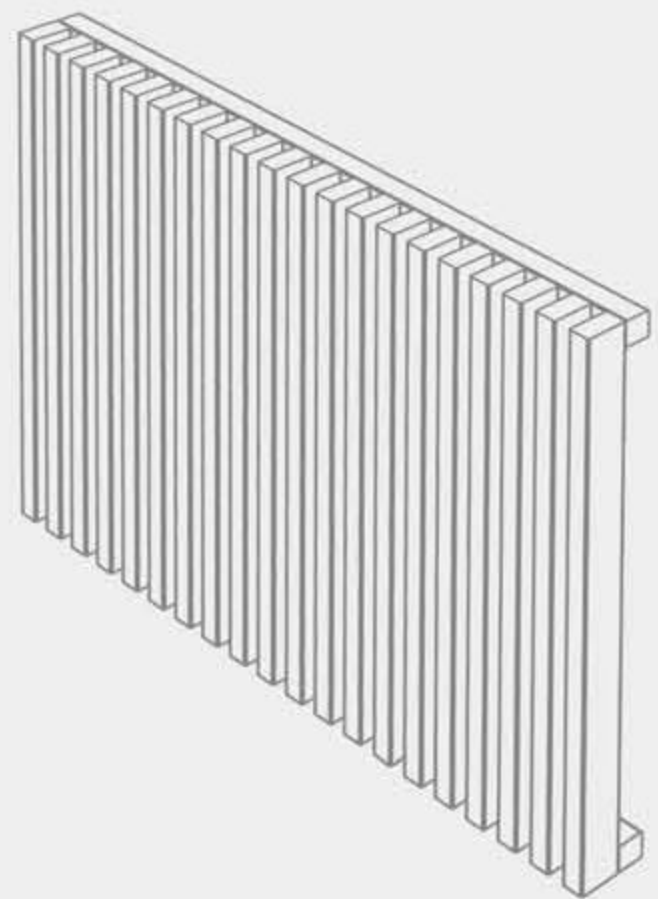

Model: C

Stainless steel DIMA Radiator

Model	Width[w]	Height(H)	No.of Blade	Output Heat		Connections
				Watts	KCal	
C5315	530	525	15	939	810	500
C7020	705	525	20	1252	1080	500
C8825	880	525	25	1566	1350	500
C10530	1055	525	30	1879	1620	500



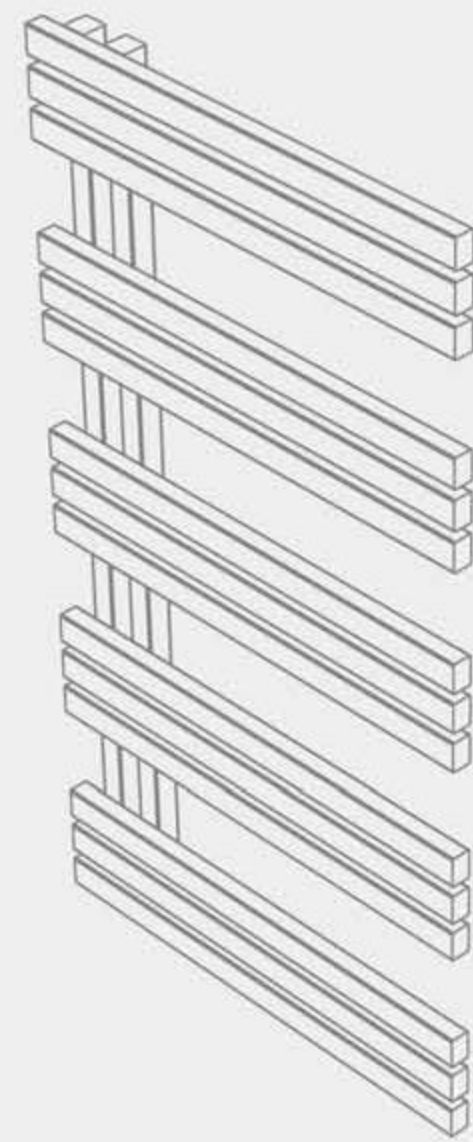

Model: E
Stainless steel DIMA Radiator

Model	Width[w]	Height(H)	No.of Blade	Output Heat		Connections
				Watts	KCal	
E9115	600	910	15	714	619	50-500



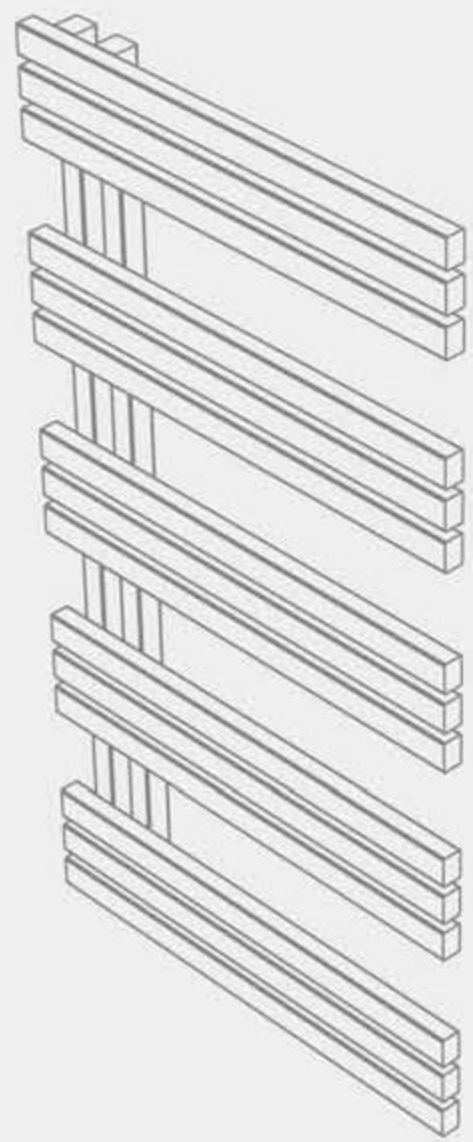

Model: E Black

Stainless steel DIMA Radiator

Model	Width[w]	Height(H)	No.of Blade	Output Heat		Connections
				Watts	KCal	
E9115	600	910	15	714	619	50-500



Model: 2E

Stainless steel DIMA Radiator

Model	Width[w]	Height(H)	No.of Blade	Output Heat		Connections
				Watts	KCal	
2E5912	600	590	12	415	358	50
2E8918	600	890	18	623	537	50
2E11924	600	1190	24	830	716	50



Model: 2SE

Stainless steel DIMA Radiator

Model	Width[w]	Height(H)	No.of Blade	Output Heat		Connections
				Watts	KCal	
2SE7412	600	740	12	415	358	50
2SE11418	600	1140	18	623	537	50
2SE15424	600	1540	24	830	716	50

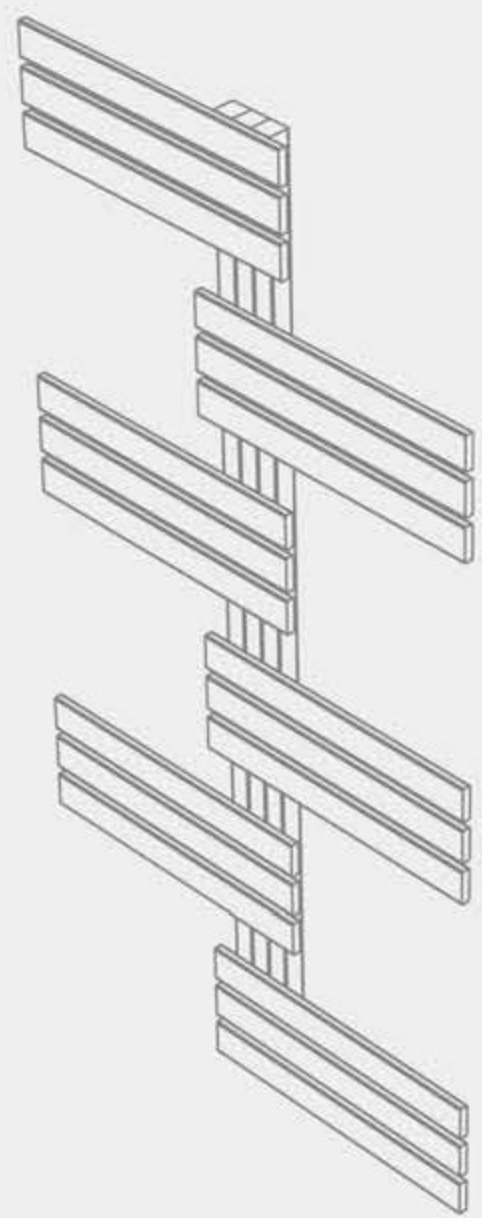

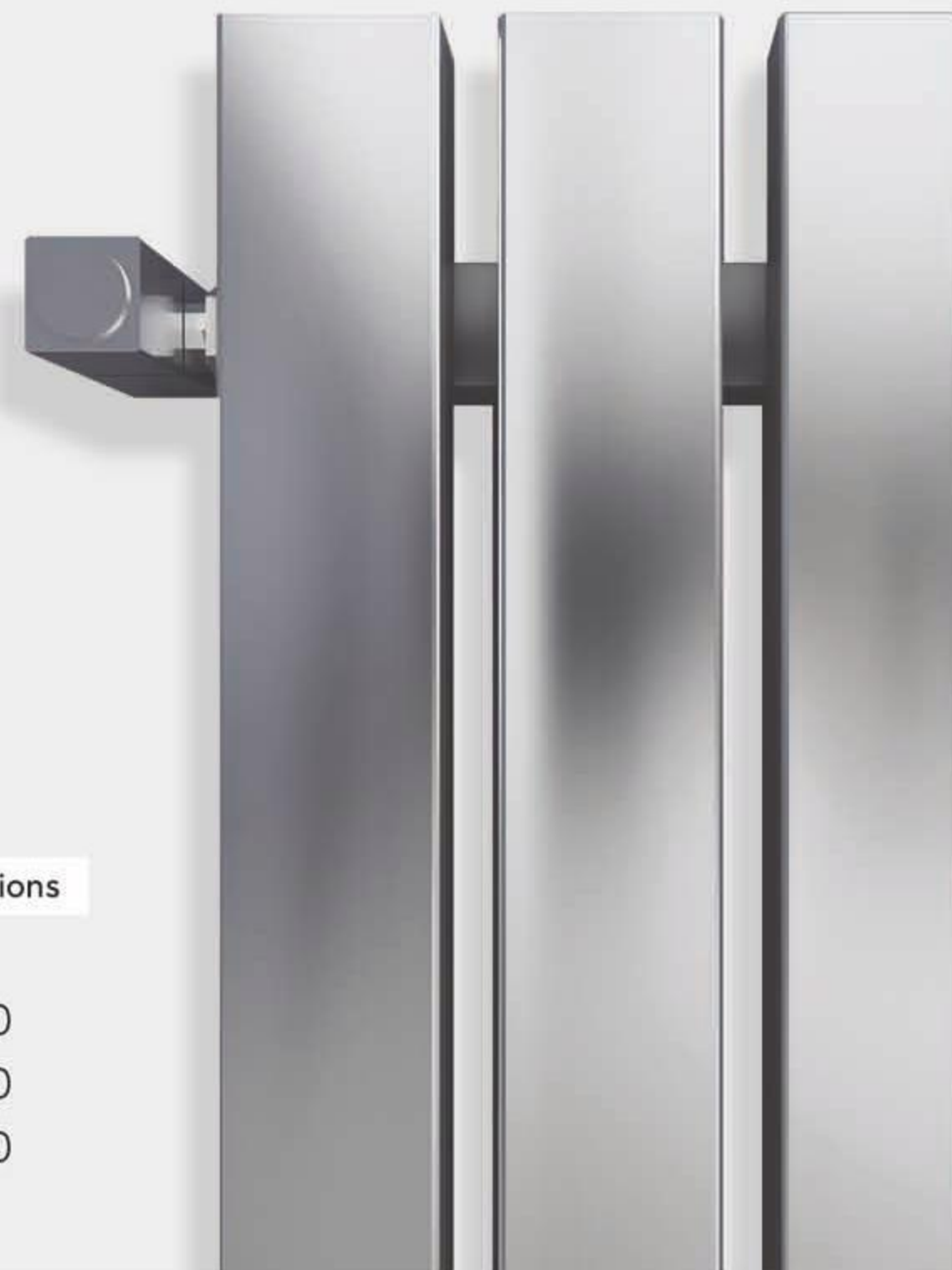
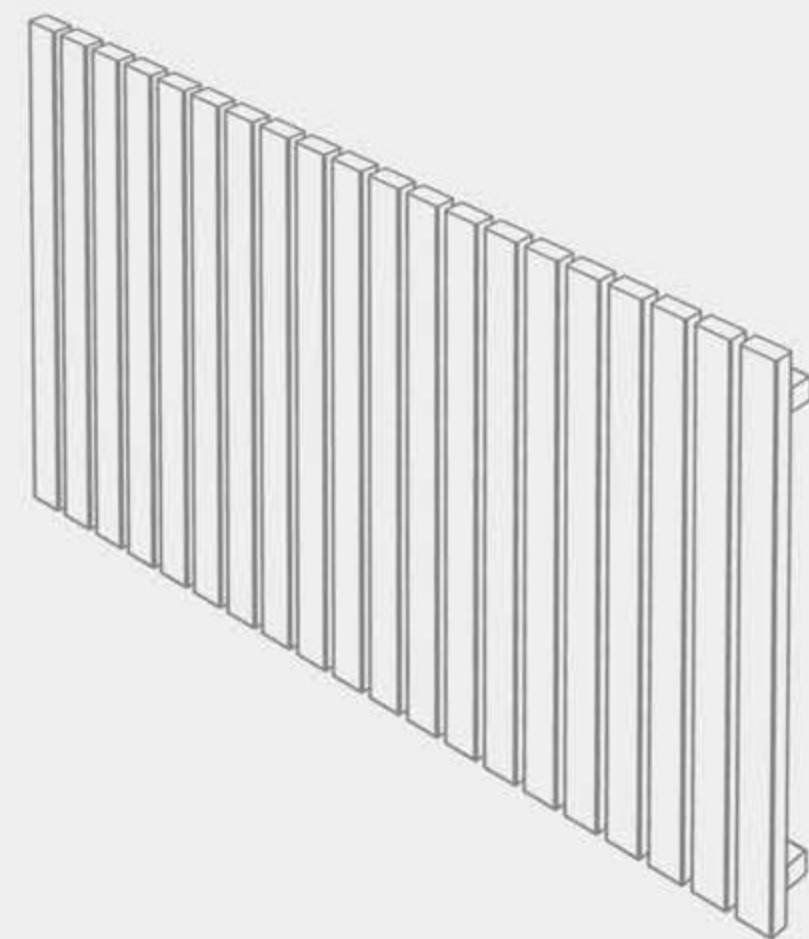

Model: F

Stainless steel DIMA Radiator

Model	Width[w]	Height(H)	No.of Blade	Output Heat			Connections
				Watts	KCal	KCal+	
F7415	740	600	15	1044	900	1080	500
F9920	990	600	20	1392	1200	1440	500
F12425	1240	600	25	1740	1500	1800	500



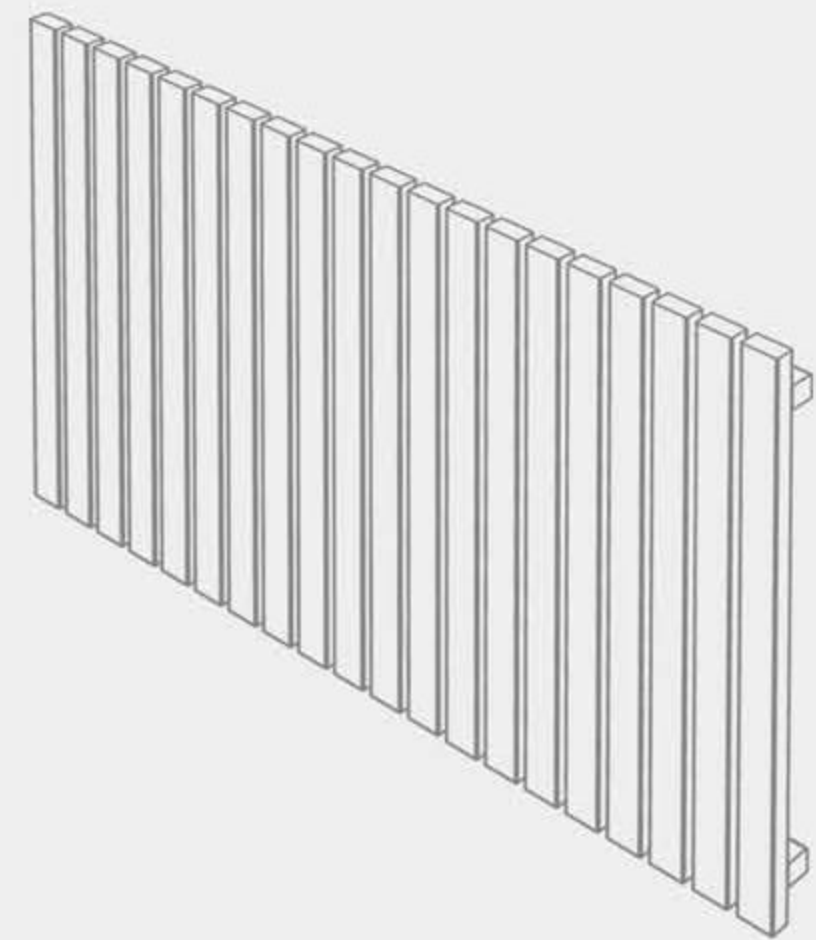

Model: F Black

Stainless steel DIMA Radiator

Model	Width[w]	Height(H)	No.of Blade	Output Heat			Connections
				Watts	KCal	KCal+	
F7415	740	600	15	1044	900	1080	500
F9920	990	600	20	1392	1200	1440	500
F12425	1240	600	25	1740	1500	1800	500

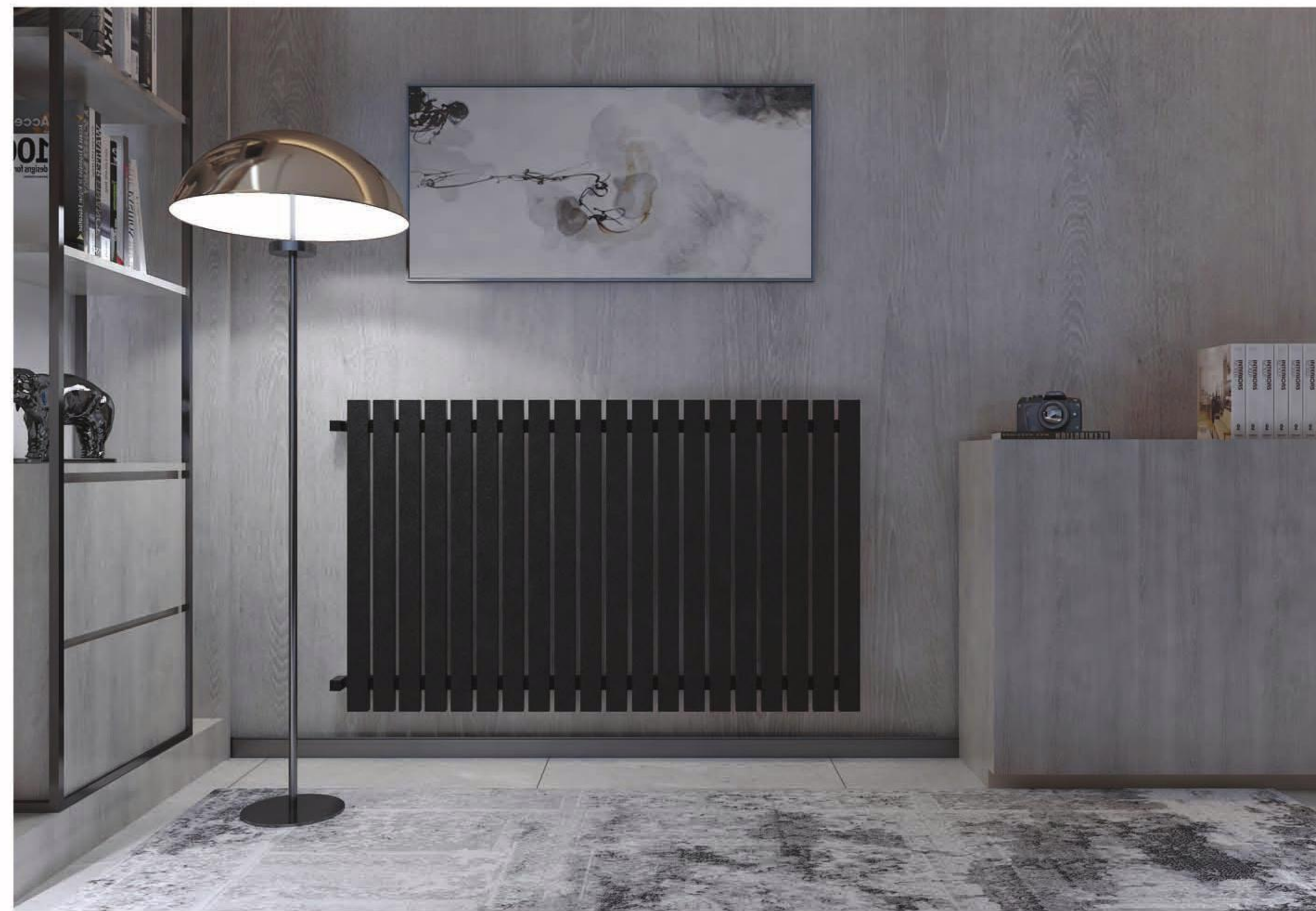

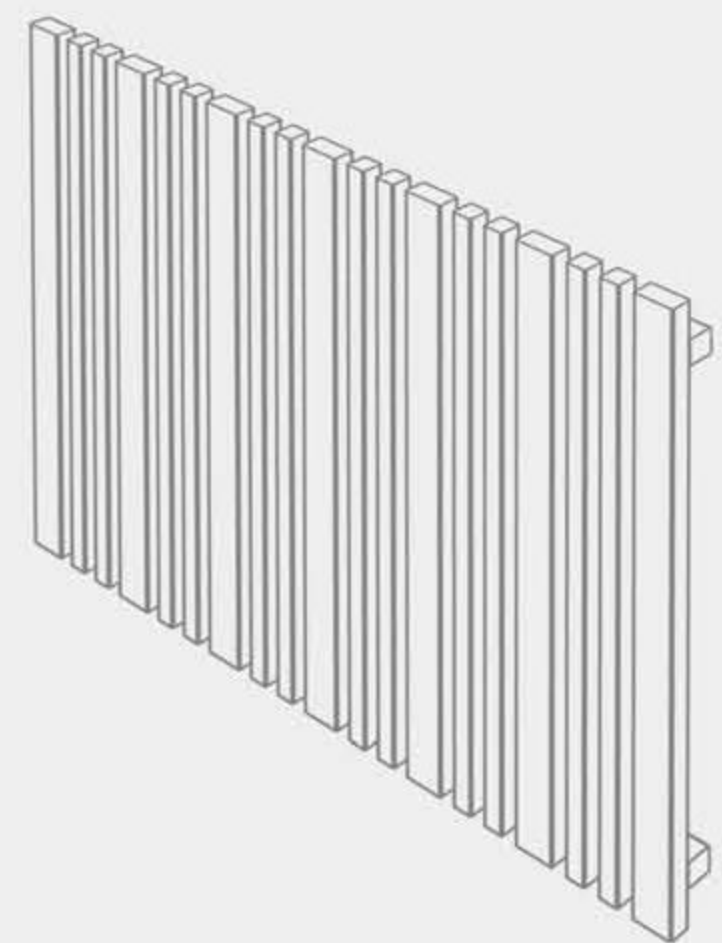

Model: FT

Stainless steel DIMA Radiator

Model	Width[w]	Height(H)	No.of Blade	Output Heat		Connections
				Watts	KCal	
FT7919	790	600	19	1183	1020	500
FT10425	1040	600	25	1554	1340	500
FT12931	1290	600	31	1925	1660	500



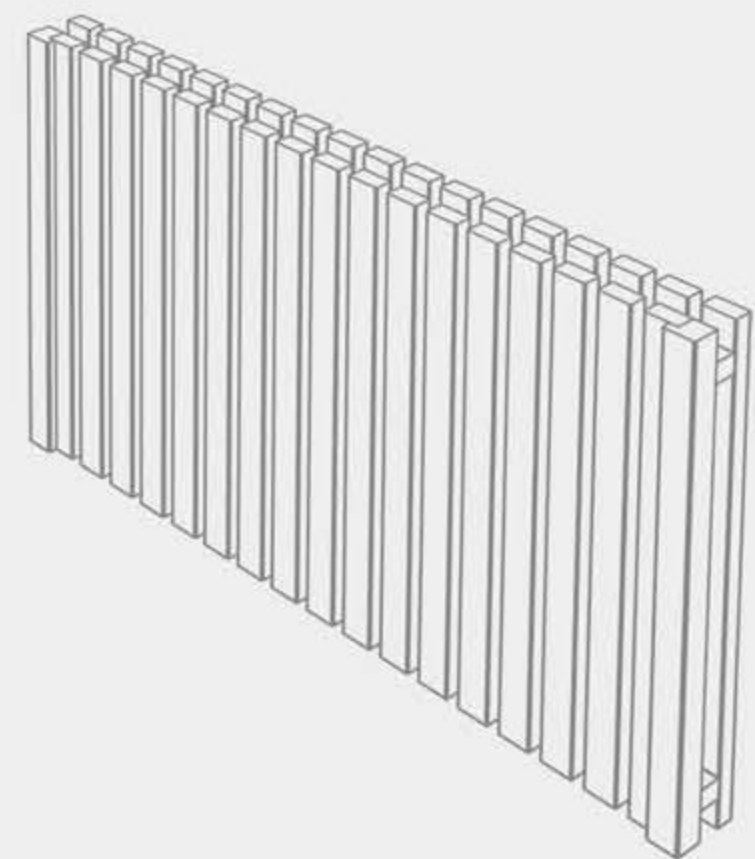

Model: 2F

Stainless steel DIMA Radiator

Model	Width[w]	Height(H)	No.of Blade	Output Heat			Connections
				Watts	KCal	KCal+	
2F8829	880	600	29	2018	1740	1914	500
2F11839	1180	600	39	2714	2340	2574	500
2F14249	1420	600	49	3410	2940	3234	500



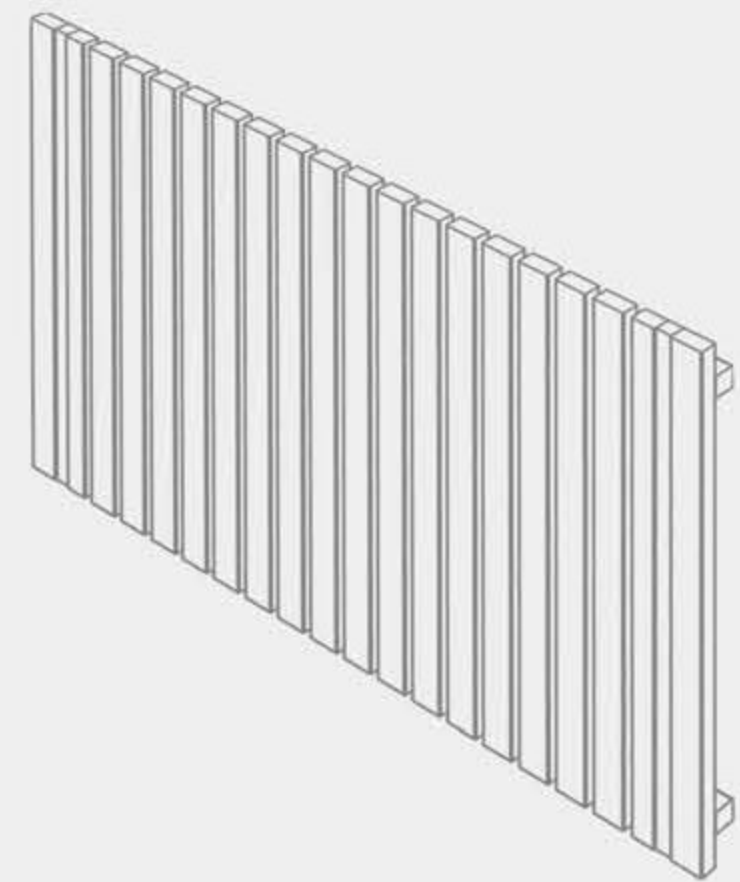

Model: FW

Stainless steel DIMA Radiator

Model	Width[w]	Height(H)	No.of Blade	Output Heat			Connections
				Watts	KCal	KCal+	
FW7415	740	600	15	1044	900	1080	500
FW9920	990	600	20	1392	1200	1440	500
FW12425	1240	600	25	1740	1500	1800	500



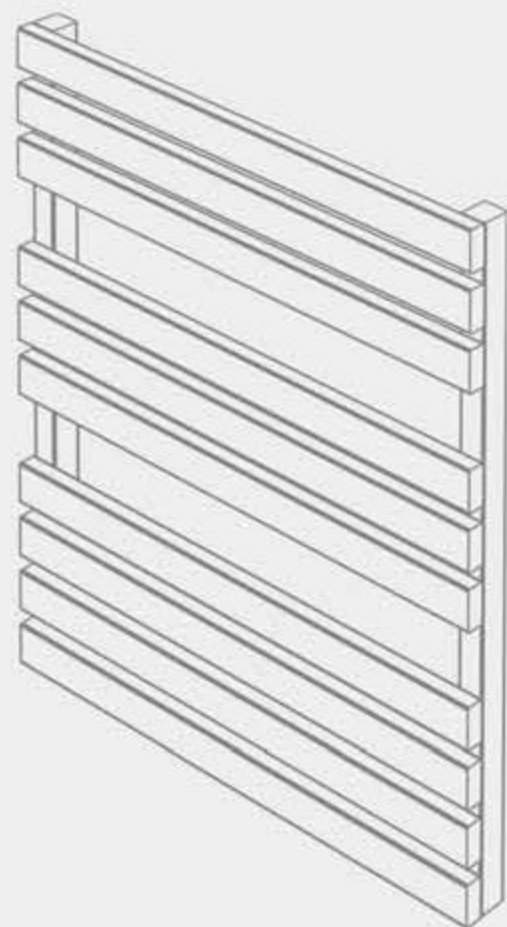

Model: H

Stainless steel DIMA Radiator

Model	Width[w]	Height(H)	No.of Blade	Output Heat		Connections
				Watts	KCal	
H5208	525	535	8	400	345	500
H5210	525	645	10	500	432	500
H5213	525	810	13	650	561	500



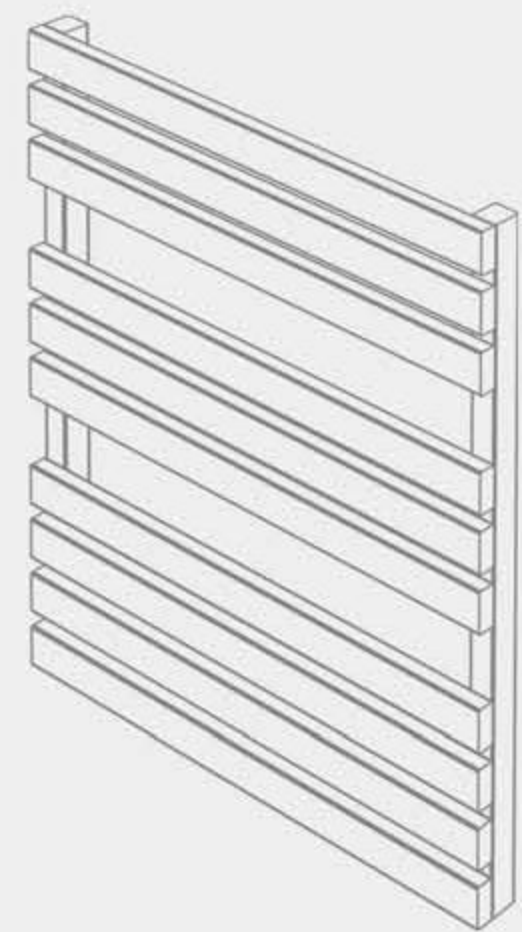

Model: H Black

Stainless steel DIMA Radiator

Model	Width[w]	Height(H)	No.of Blade	Output Heat		Connections
				Watts	KCal	
H5208	525	535	8	400	345	500
H5210	525	645	10	500	432	500
H5213	525	810	13	650	561	500



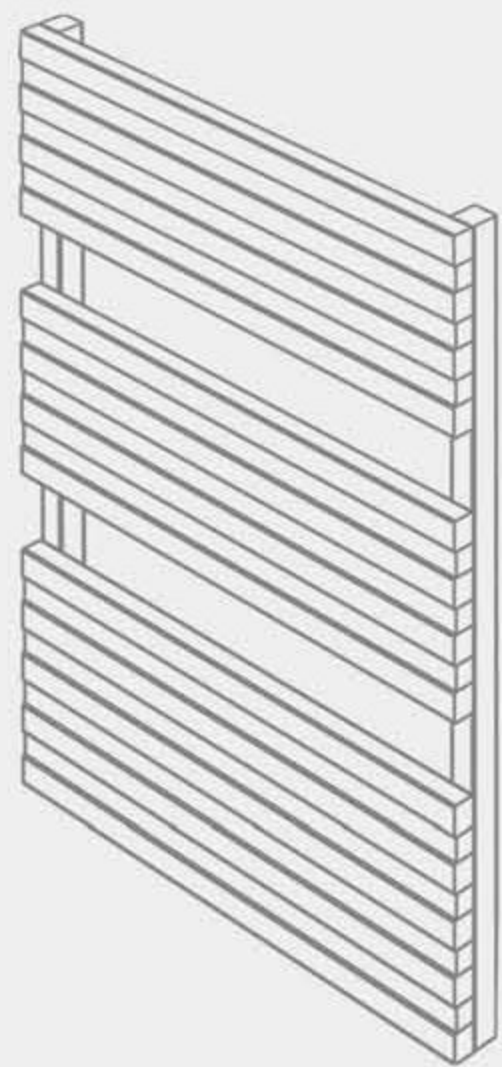

Model: **HW**

Stainless steel DIMA Radiator

Model	Width[w]	Height(H)	No.of Blade	Output Heat		Connections
				Watts	KCal	
HW5208	525	535	8	400	345	500
HW5210	525	645	10	500	432	500
HW5213	525	810	13	650	561	500



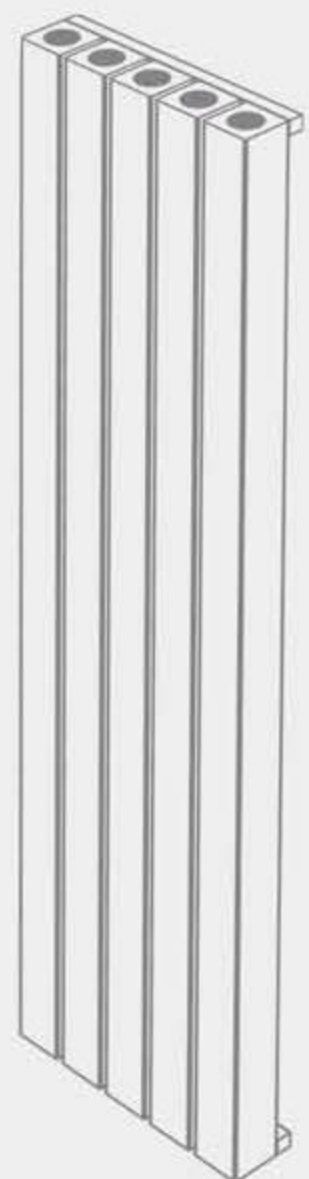

Model: I

Stainless steel DIMA Radiator

Model	Width[w]	Height(H)	No.of Blade	Output Heat			Connections
				Watts	KCal	KCal+	
I2603	260	1800	3	2376	2044	2452	340
I3504	350	1800	4	3168	2726	3271	430
I4405	440	1800	5	3960	3408	4089	520
I5306	530	1800	6	4752	4089	4906	610



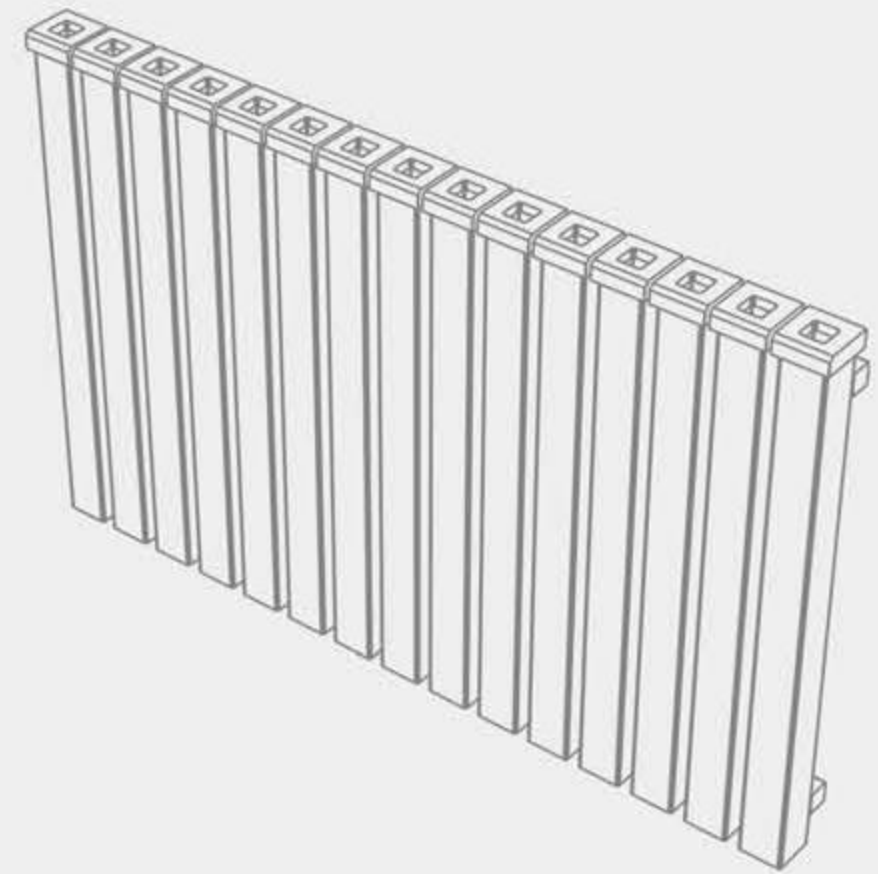

Model: IS

Stainless steel DIMA Radiator

Model	Width[w]	Height(H)	No.of Blade	Output Heat			Connections
				Watts	KCal	KCal+	
IS6310	635	600	10	1740	1500	1800	500
IS9615	960	600	15	2610	2250	2700	500
IS12820	1285	600	20	3480	3000	3600	500



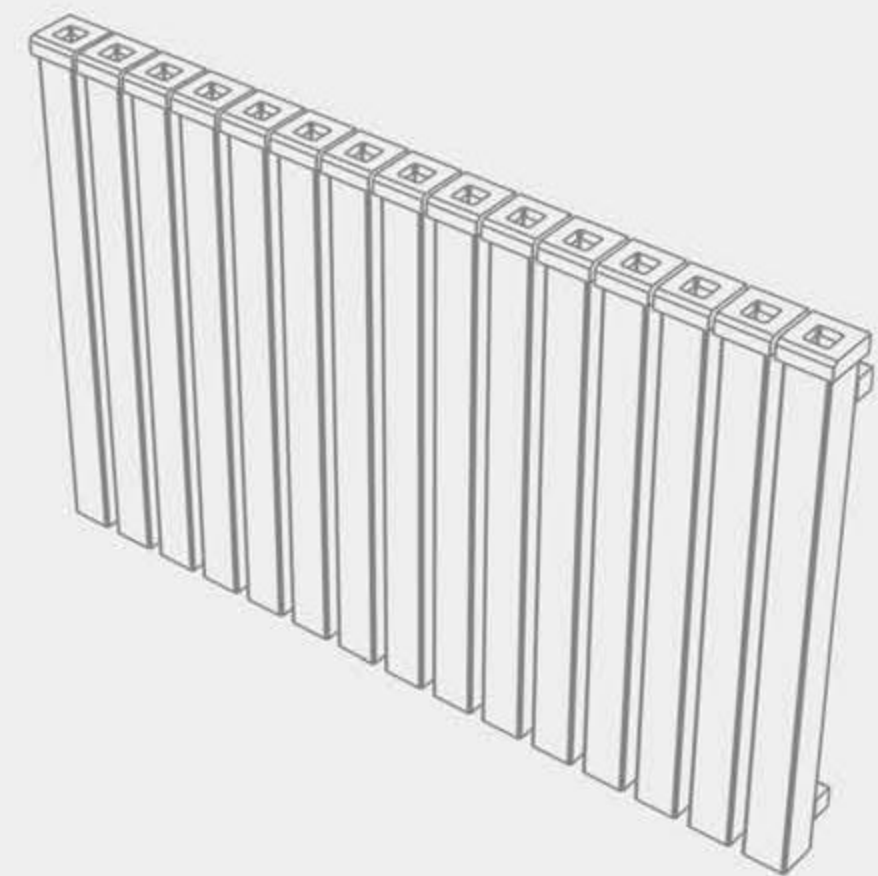

Model: IS Black

Stainless steel DIMA Radiator

Model	Width[w]	Height(H)	No.of Blade	Output Heat			Connections
				Watts	KCal	KCal+	
IS6310	635	600	10	1740	1500	1800	500
IS9615	960	600	15	2610	2250	2700	500
IS12820	1285	600	20	3480	3000	3600	500



Model: ISL

Stainless steel DIMA Radiator

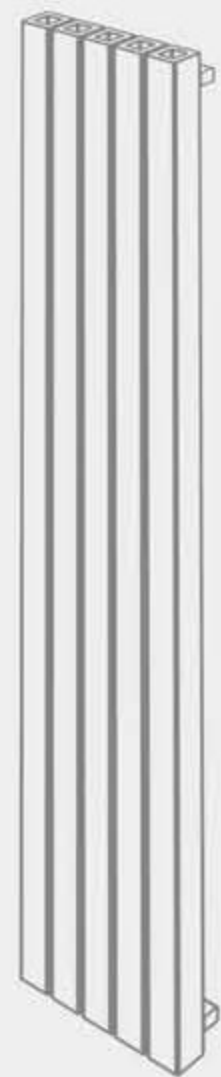

Model	Width[w]	Height(H)	No.of Blade	Output Heat			Connections
				Watts	KCal	KCal+	
ISL1803	180	1800	3	1566	1350	1620	260
ISL2404	245	1800	4	2088	1800	2160	325
ISL3105	310	1800	5	2610	2250	2700	390
ISL3706	375	1800	6	3132	2700	3240	455
ISL4407	440	1800	7	3654	3150	3780	520
ISL5008	505	1800	8	4176	3600	4320	585



Model: ISL Black

Stainless steel DIMA Radiator

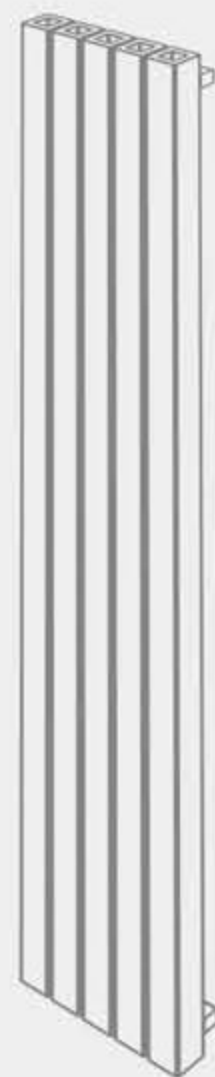

Model	Width[w]	Height(H)	No.of Blade	Output Heat			Connections
				Watts	KCal	KCal+	
ISL1803	180	1800	3	1566	1350	1620	260
ISL2404	245	1800	4	2088	1800	2160	325
ISL3105	310	1800	5	2610	2250	2700	390
ISL3706	375	1800	6	3132	2700	3240	455
ISL4407	440	1800	7	3654	3150	3780	520
ISL5008	505	1800	8	4176	3600	4320	585



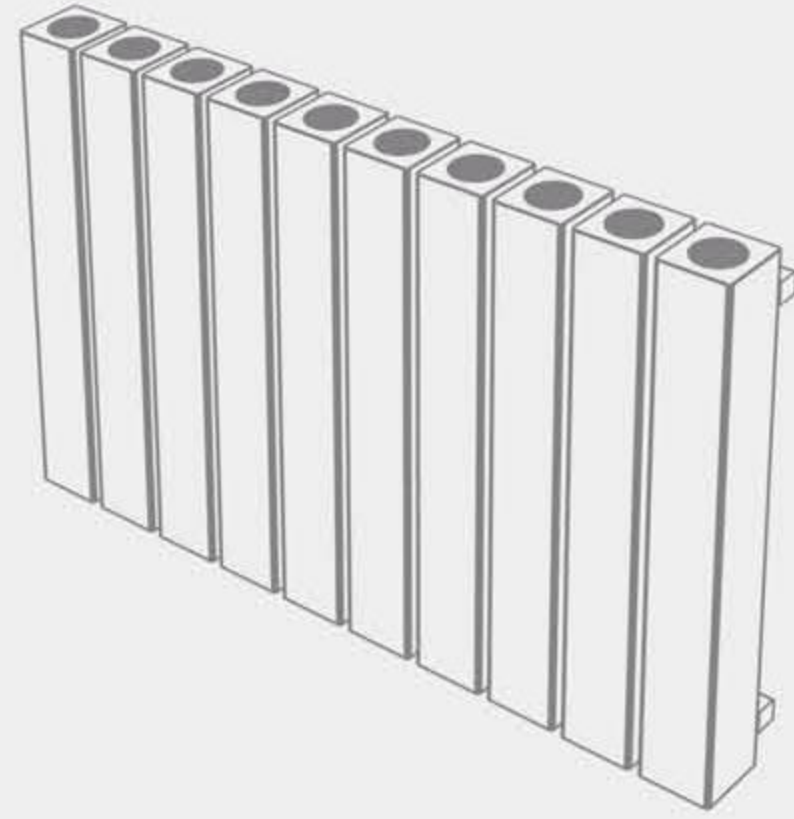

Model: IC Gray

Stainless steel DIMA Radiator

Model	Width[w]	Height(H)	No. of Blade	Output Heat			Connections
				Watts	KCal	KCal+	
IC5306	530	600	6	1584	1360	1632	500
IC7108	710	600	8	2112	1816	2179	500
IC8910	890	600	10	2640	2271	2724	500



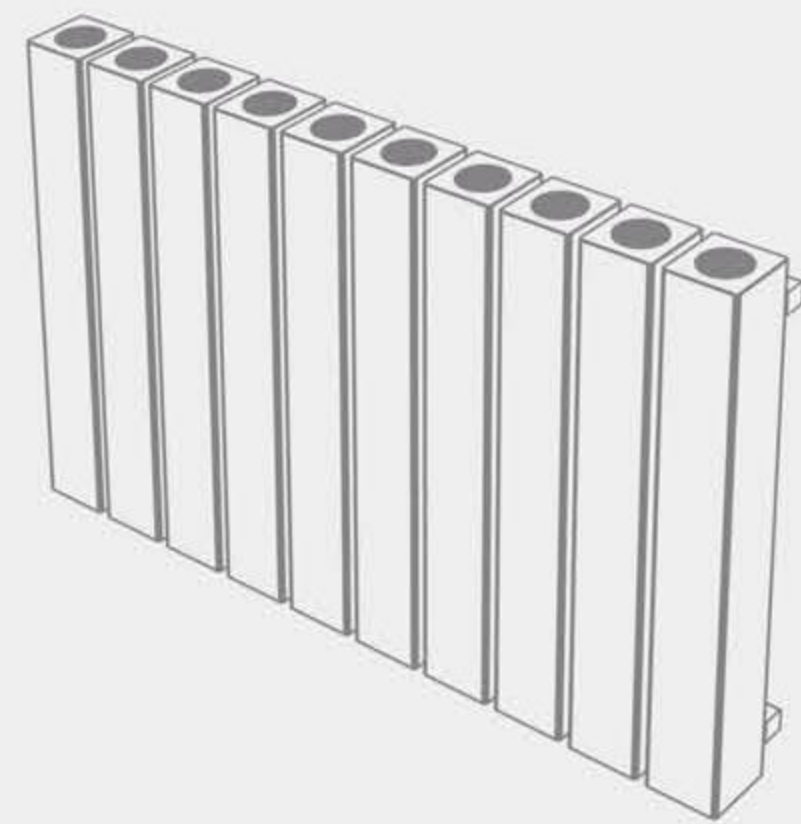

Model: IC Black

Stainless steel DIMA Radiator

Model	Width[w]	Height(H)	No.of Blade	Output Heat			Connections
				Watts	KCal	KCal+	
IC5306	530	600	6	1584	1360	1632	500
IC7108	710	600	8	2112	1816	2179	500
IC8910	890	600	10	2640	2271	2724	500

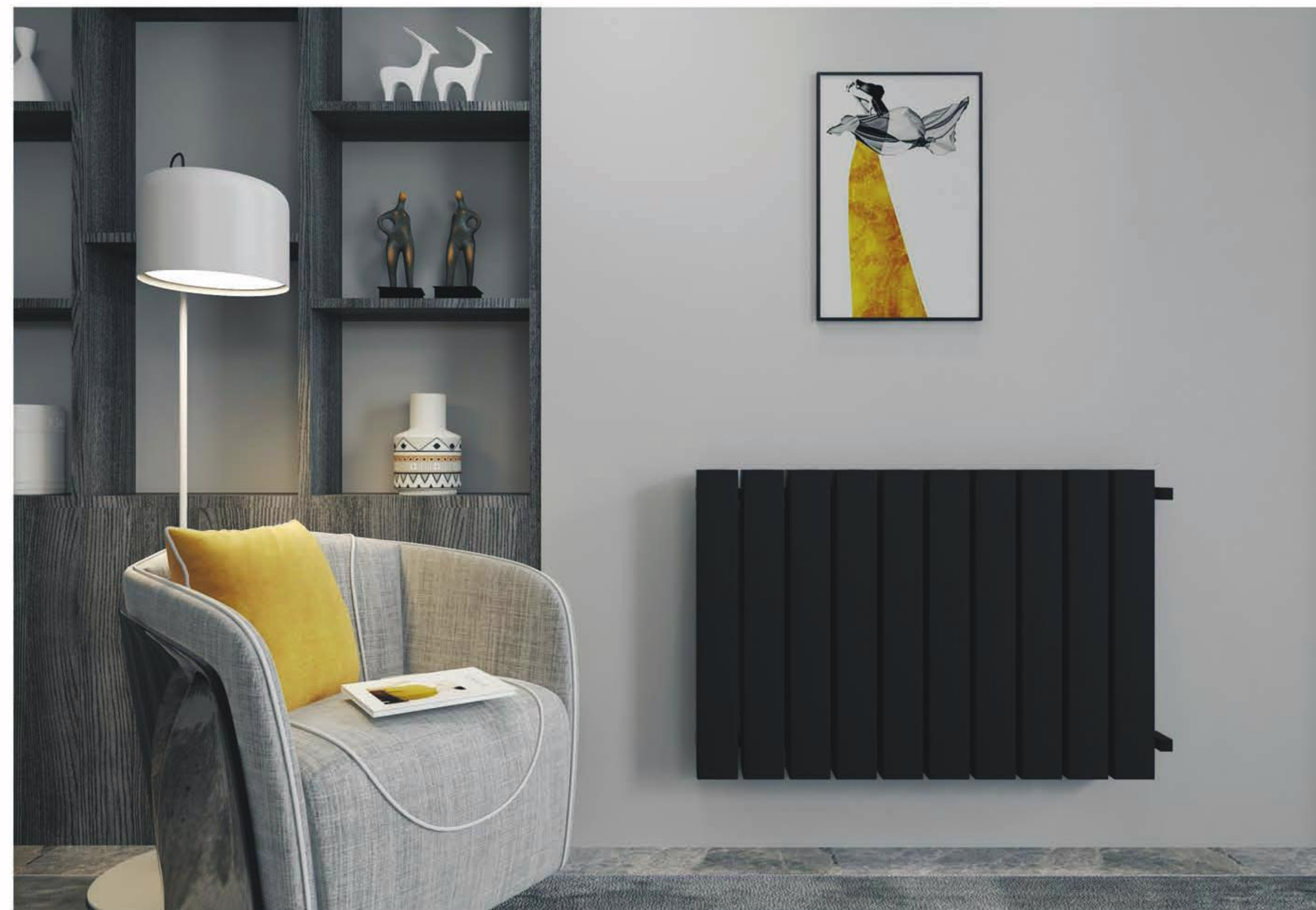

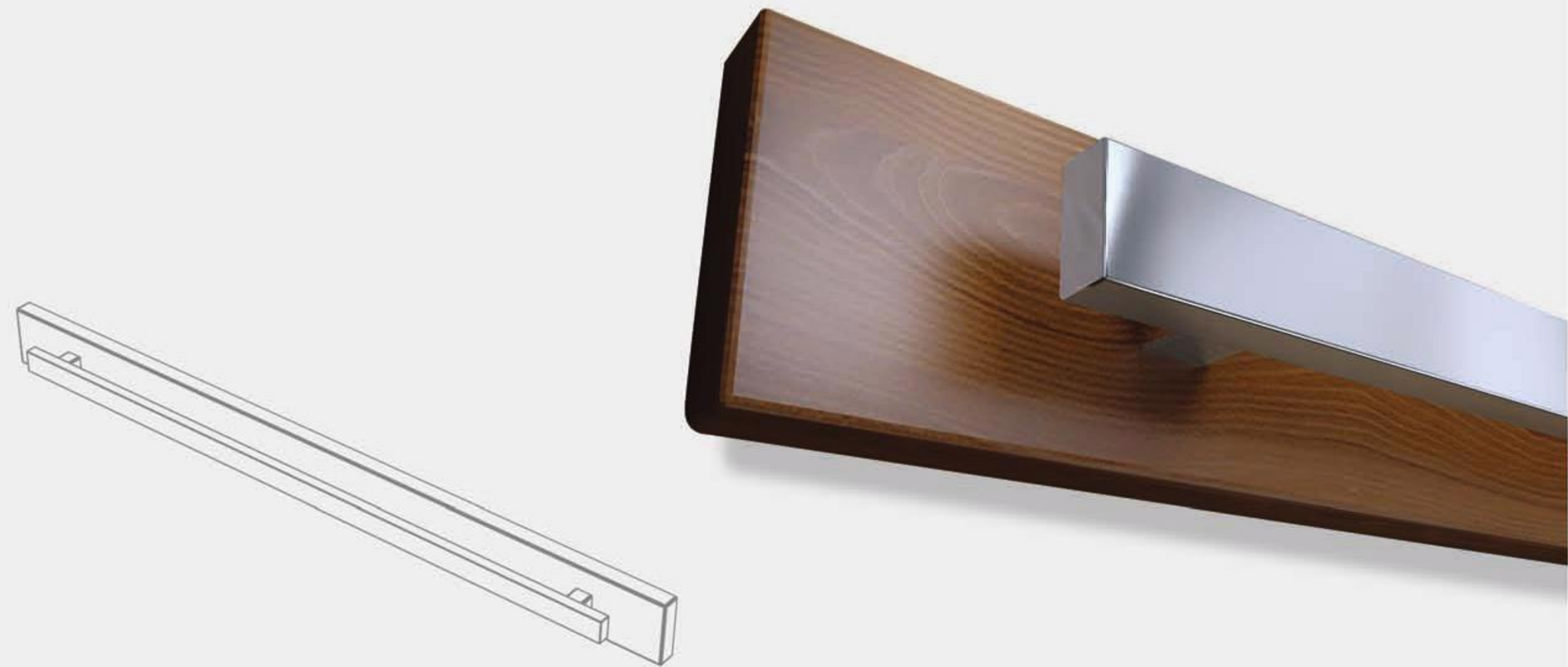

Model: **LI**
Stainless steel DIMA Radiator

Model	Width[w]	Height(H)	No.of Blade	Output Heat		Connections
				Watts	KCal	
LI1501	1500	40	1	114	98	1500



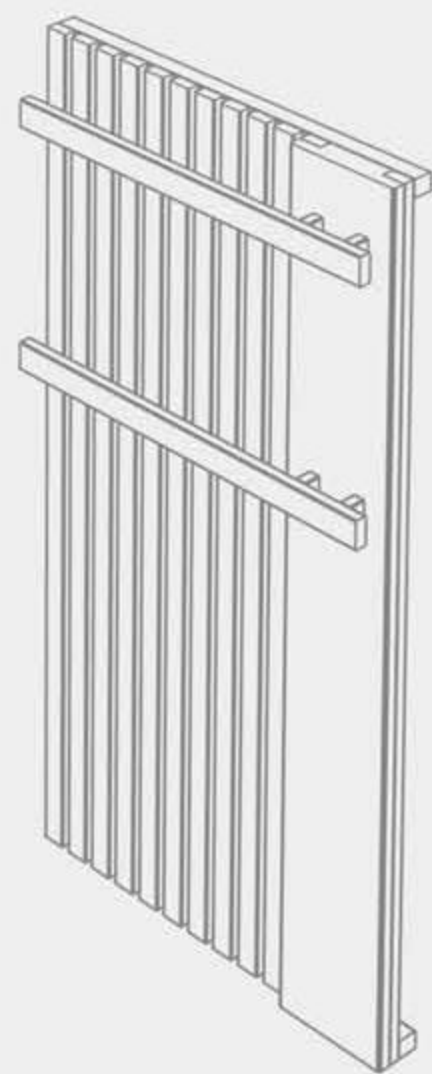

Model: **L&LW**

Stainless steel DIMA Radiator

Model	Width[w]	Height(H)	No.of Blade	Output Heat		Connections
				Watts	KCal	
L5512	550	1200	12	1440	1200	500



Model: **L**

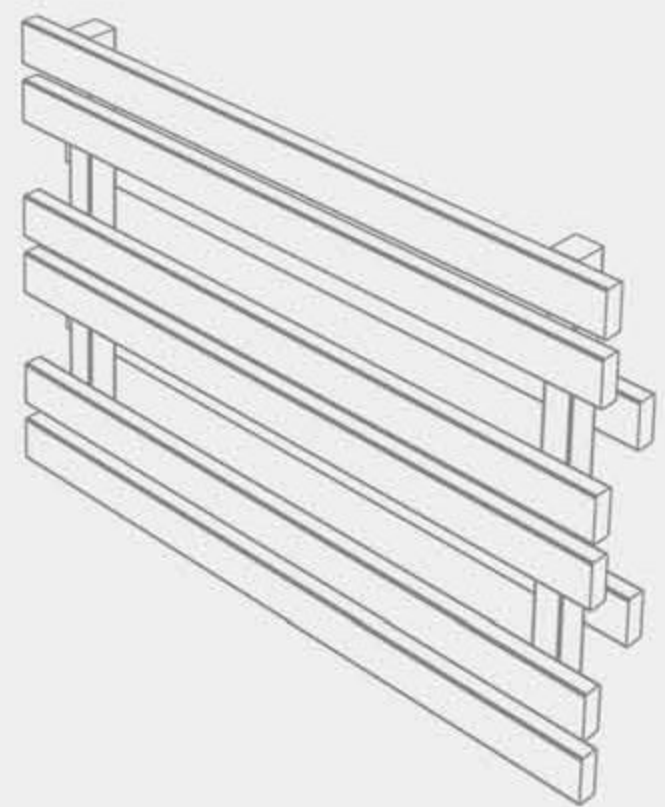

Model: M&MW
Stainless steel DIMA Radiator

Model	Width[w]	Height(H)	No.of Blade	Output Heat		Connections
				Watts	KCal	
MW6008	600	425	8	556	480	500
MW6010	600	535	10	696	600	500



Model: MA

Stainless steel DIMA Radiator

Model	Width[w]	Height(H)	No.of Blade	Output Heat			Connections
				Watts	KCal	KCal+	
MA4110	410	1300	10	1108	954	1144	490
MA4912	490	1300	12	1329	1144	1372	570
MA6115	610	1300	15	2078	1430	1716	690
MA8120	810	1300	20	2217	1908	2289	890

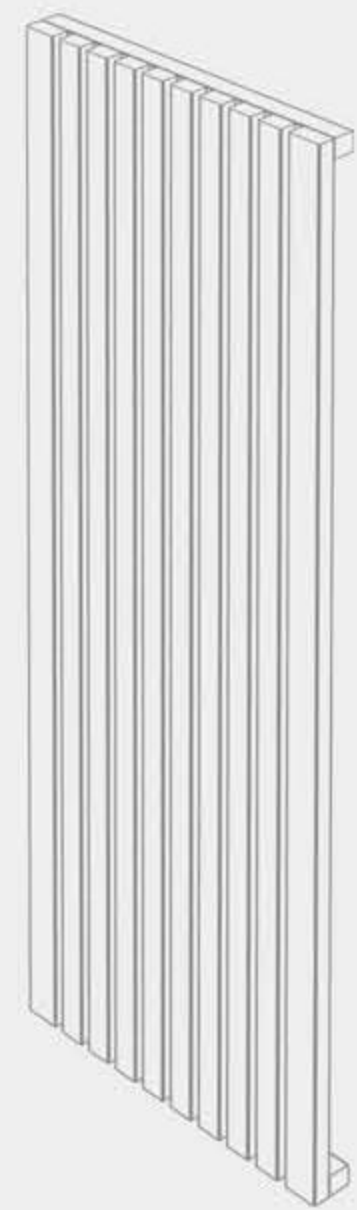

Model: **NA**

Stainless steel DIMA Radiator

Model	Width[w]	Height(H)	No.of Blade	Output Heat			Connections
				Watts	KCal	KCal+	
NA1903	190	1800	3	776	675	810	270
NA2504	255	1800	4	1030	900	1080	335
NA3205	320	1800	5	1290	1125	1350	400
NA3806	385	1800	6	1550	1350	1620	465
NA4507	450	1800	7	1810	1575	1890	530



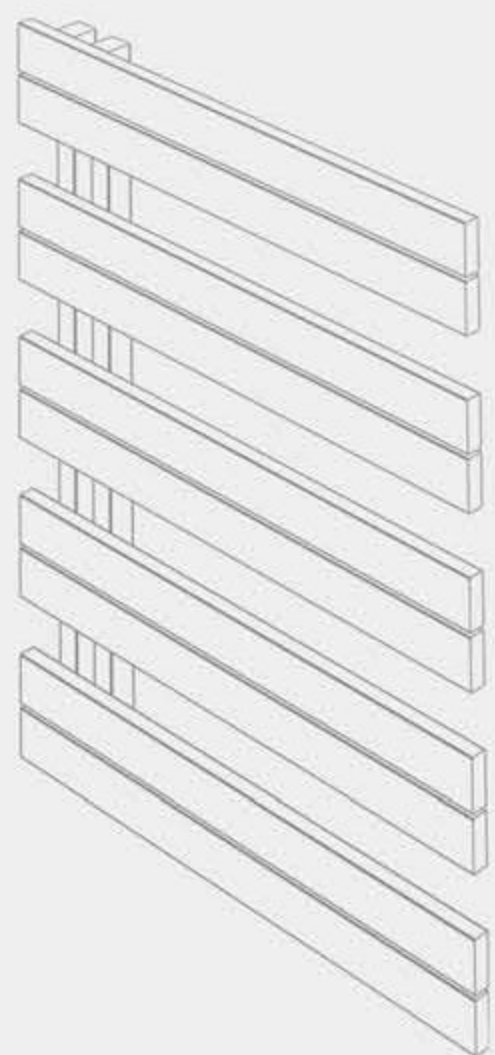

Model: NE
Stainless steel DIMA Radiator

Model	Width[w]	Height(H)	No.of Blade	Output Heat		Connections
				Watts	KCal	
NE9010	600	900	10	793	687	50-500



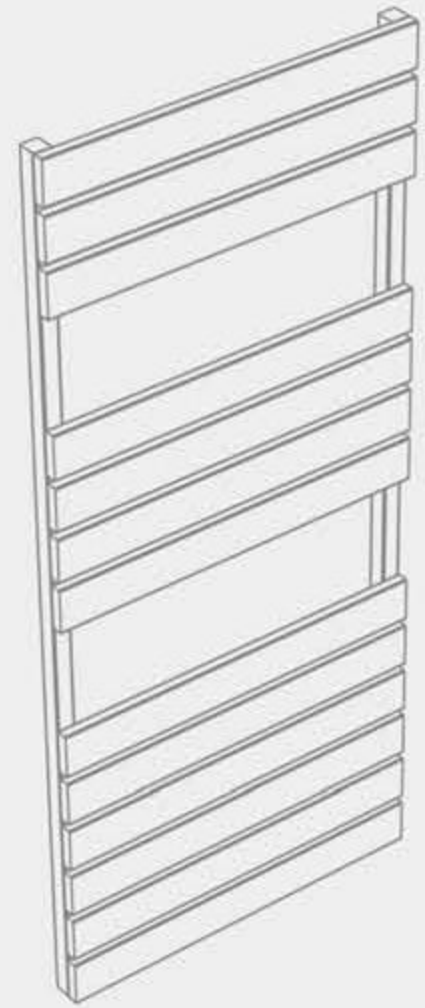

Model: NH

Stainless steel DIMA Radiator

Model	Width[w]	Height(H)	No.of Blade	Output Heat		Connections
				Watts	KCal	
NH5208	525	680	8	600	520	500
NH5210	525	825	10	747	650	500
NH5213	525	1030	13	970	845	500
NH5215	525	1150	15	1120	975	500



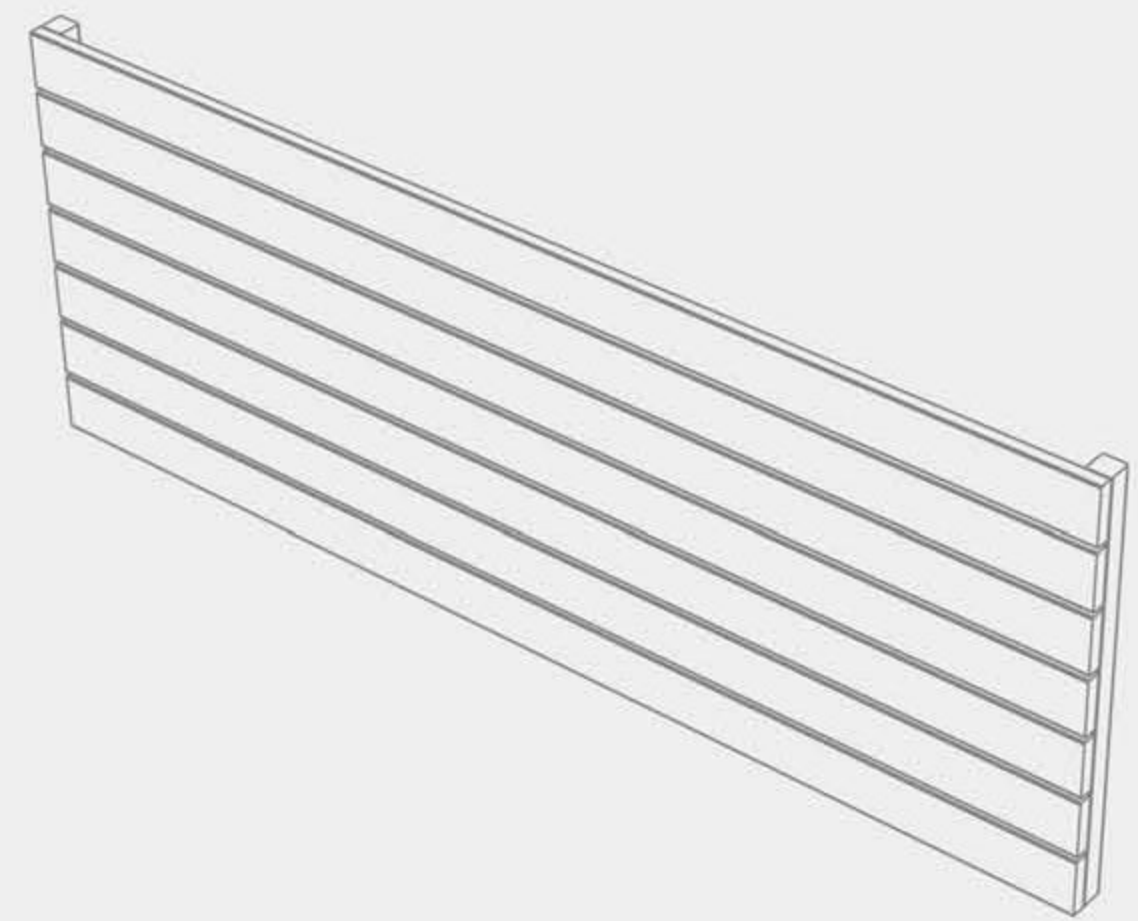

Model: NW
Stainless steel DIMA Radiator

Model	Width[w]	Height(H)	No.of Blade	Output Heat		Connections
				Watts	KCal	
NW12007	1200	450	7	1206	1050	1165



Model: P

Stainless steel DIMA Radiator

Model	Width[w]	Height(H)	No.of Blade	Output Heat		Connections
				Watts	KCal	
P3208	320	1800	8	1584	1363	400
P4010	400	1800	10	1980	1704	480
P4812	480	1800	12	2376	2044	560

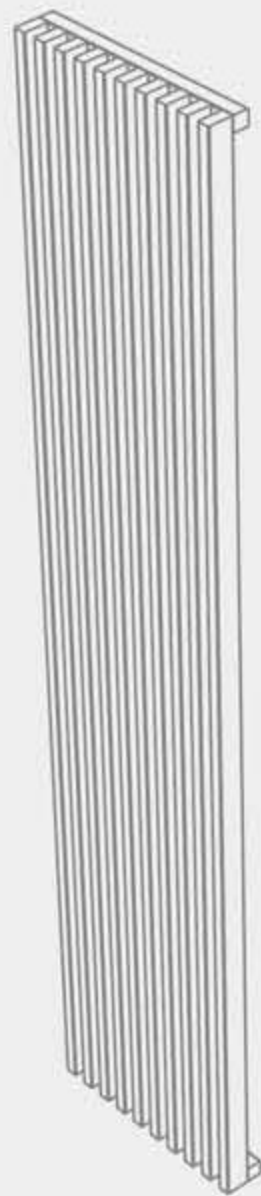

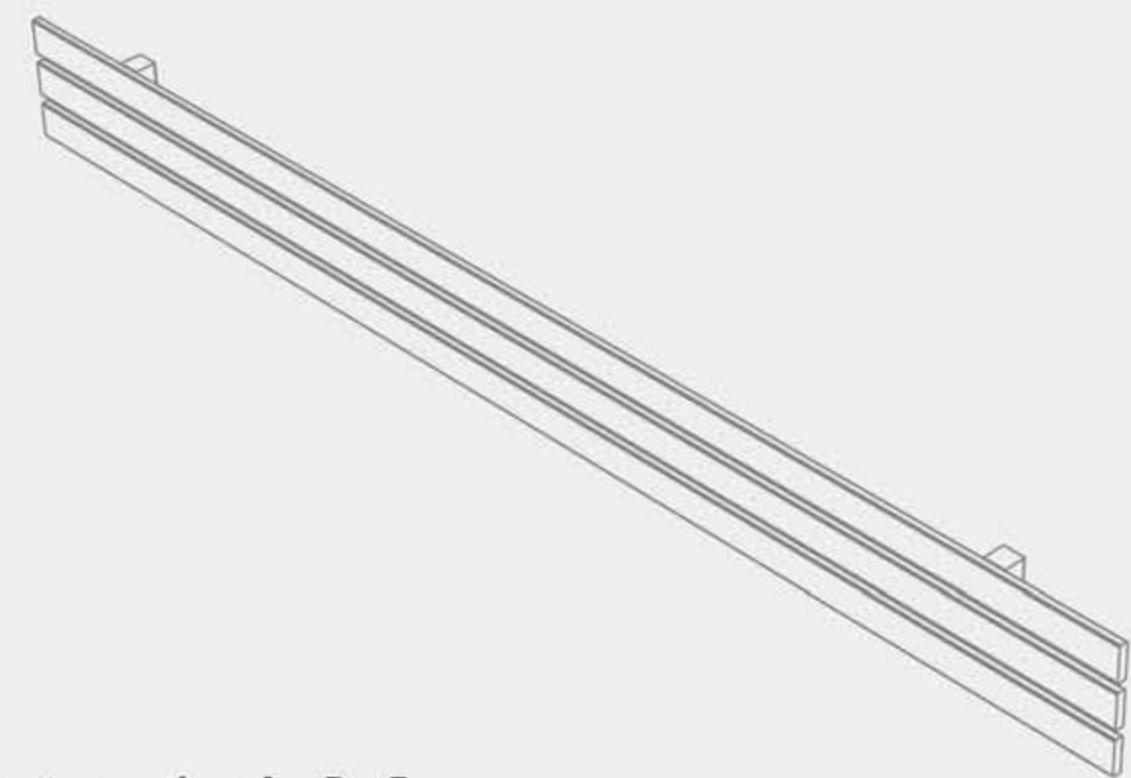

Model: V

Stainless steel DIMA Radiator

Model	Width[w]	Height(H)	No.of Blade	Output Heat		Connections
				Watts	KCal	
V1502	1500	90	2	238	205	1165
V1503	1500	140	3	357	308	1165
V1504	1500	190	4	476	411	1165
V1505	1500	240	5	595	514	1165



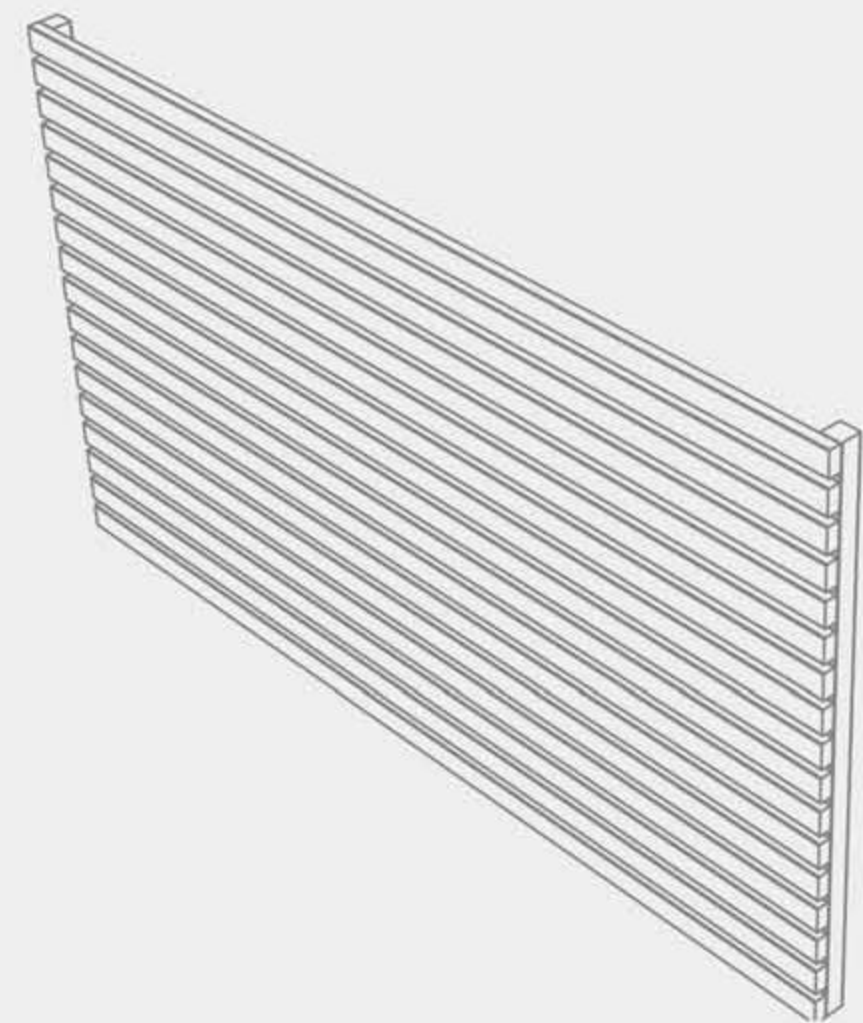

Model: W
Stainless steel DIMA Radiator

Model	Width[w]	Height(H)	No.of Blade	Output Heat		Connections
				Watts	KCal	
W12017	1200	670	17	1620	1404	1165



COLOR

you can choose



026	
401	
351	
392	
035	
472	
177	
311	
353	
458	
125	
384	

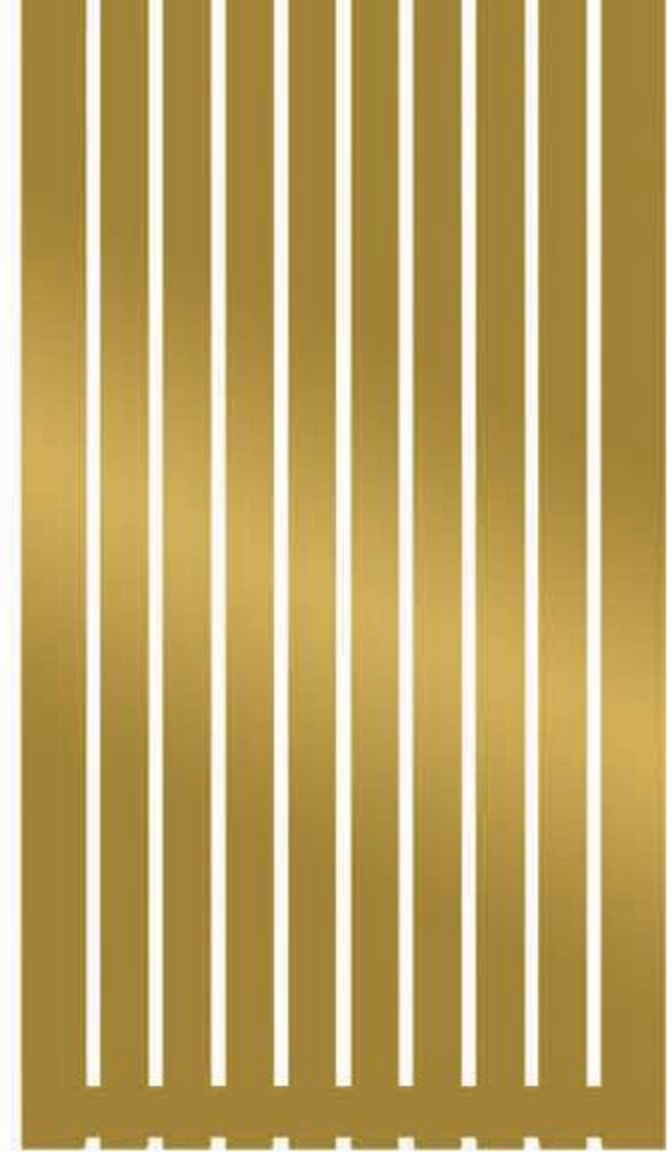

GOLDEN RADIATORS

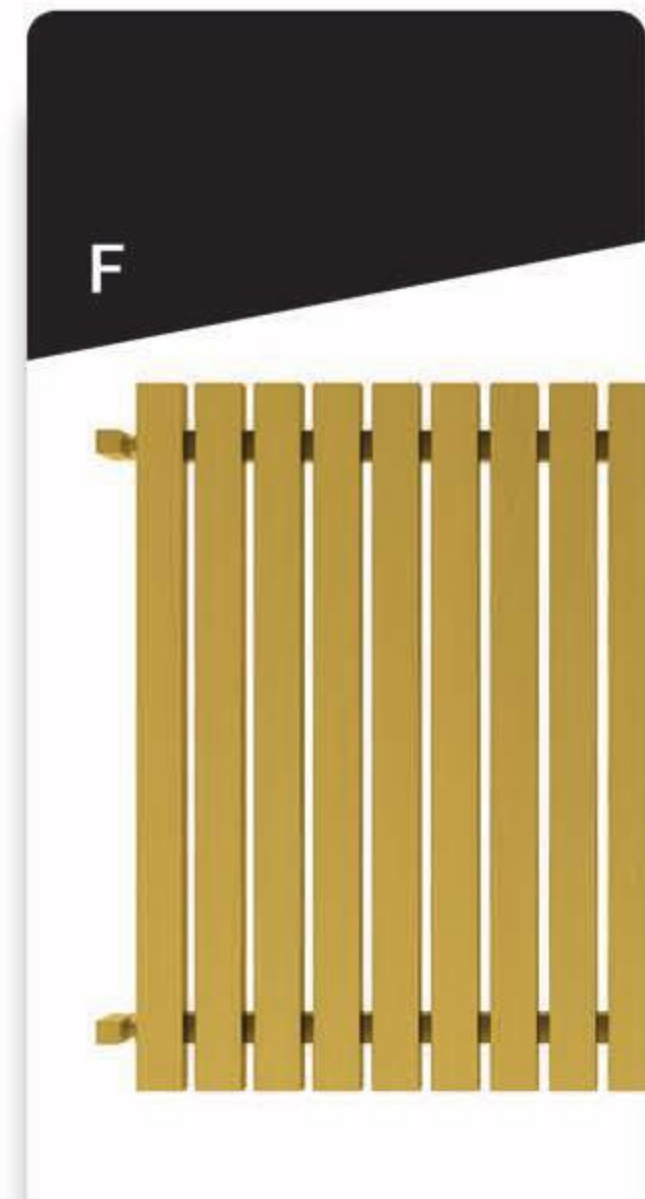
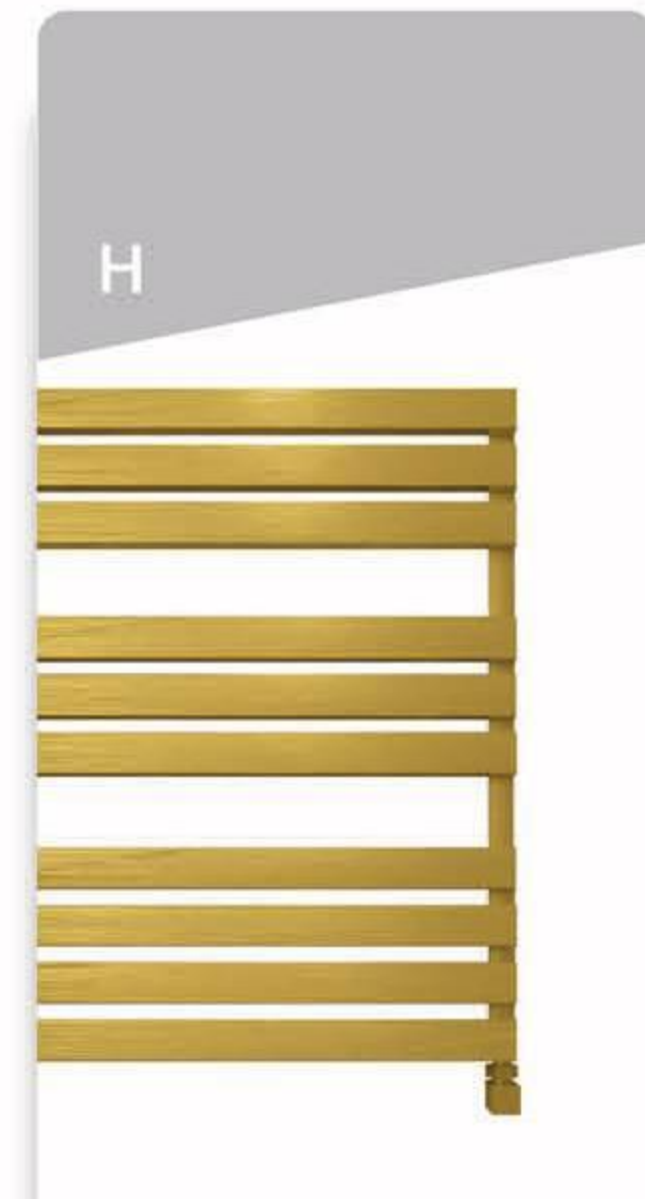
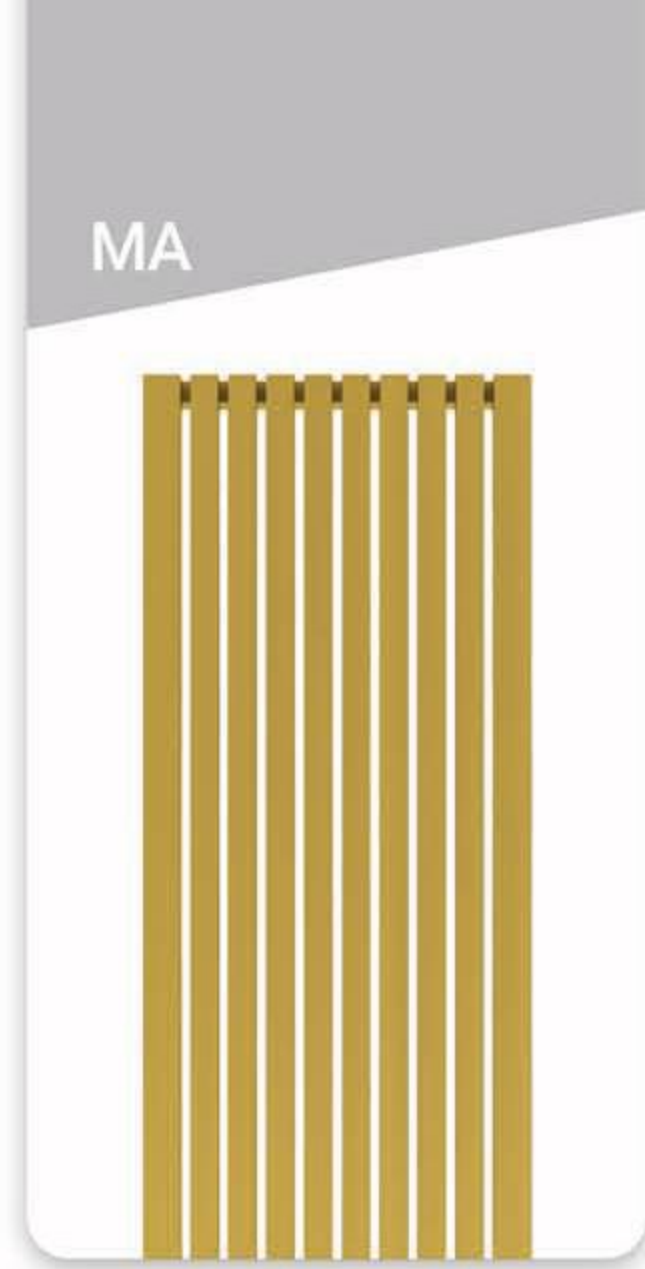
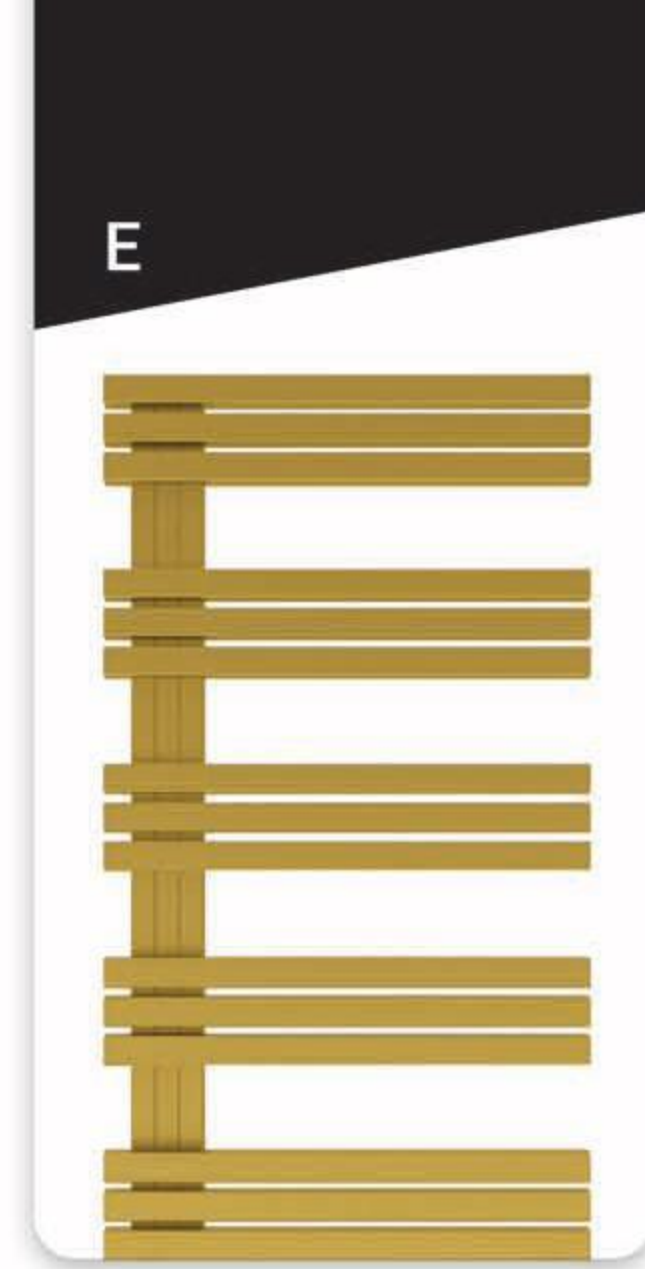

INDEX

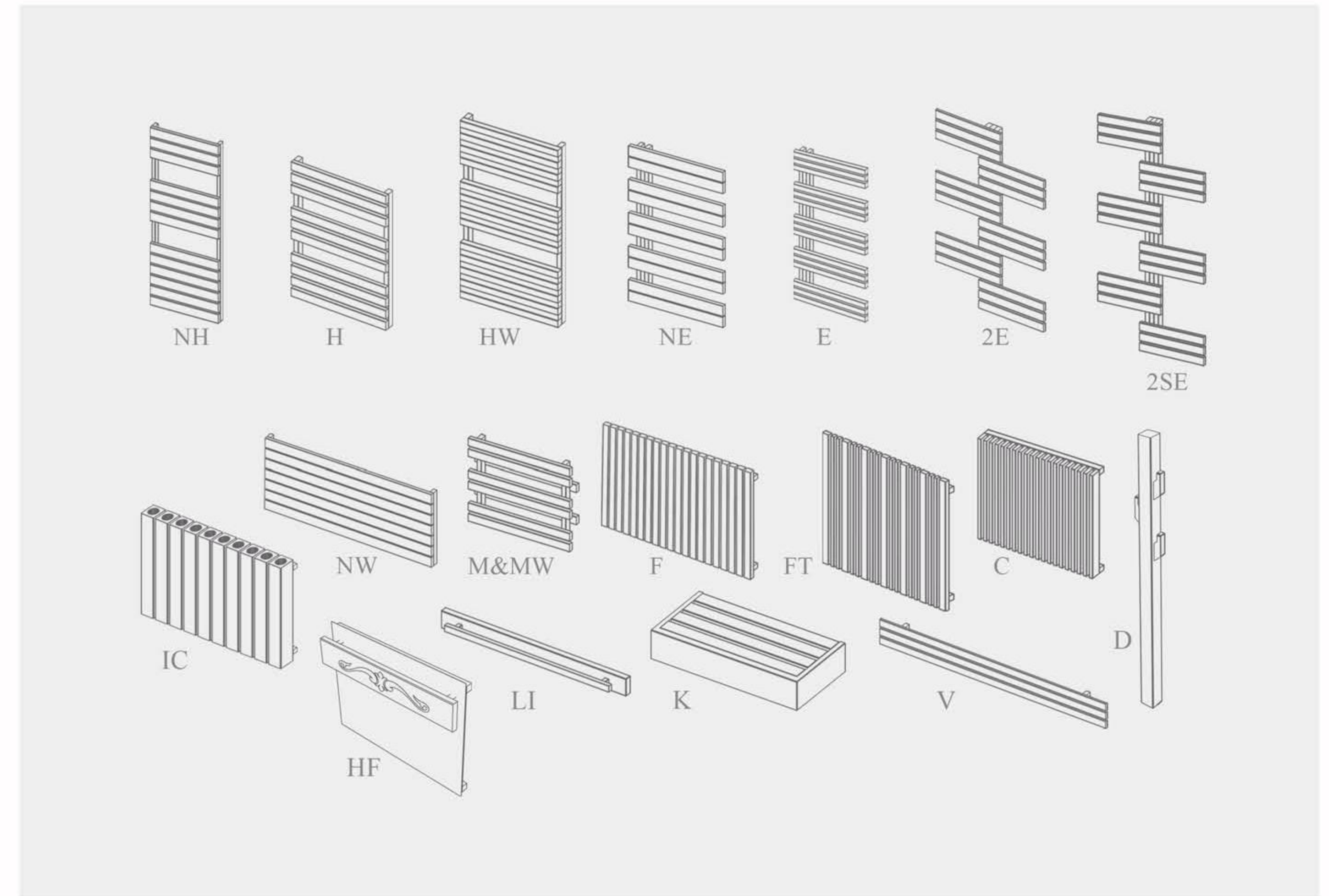
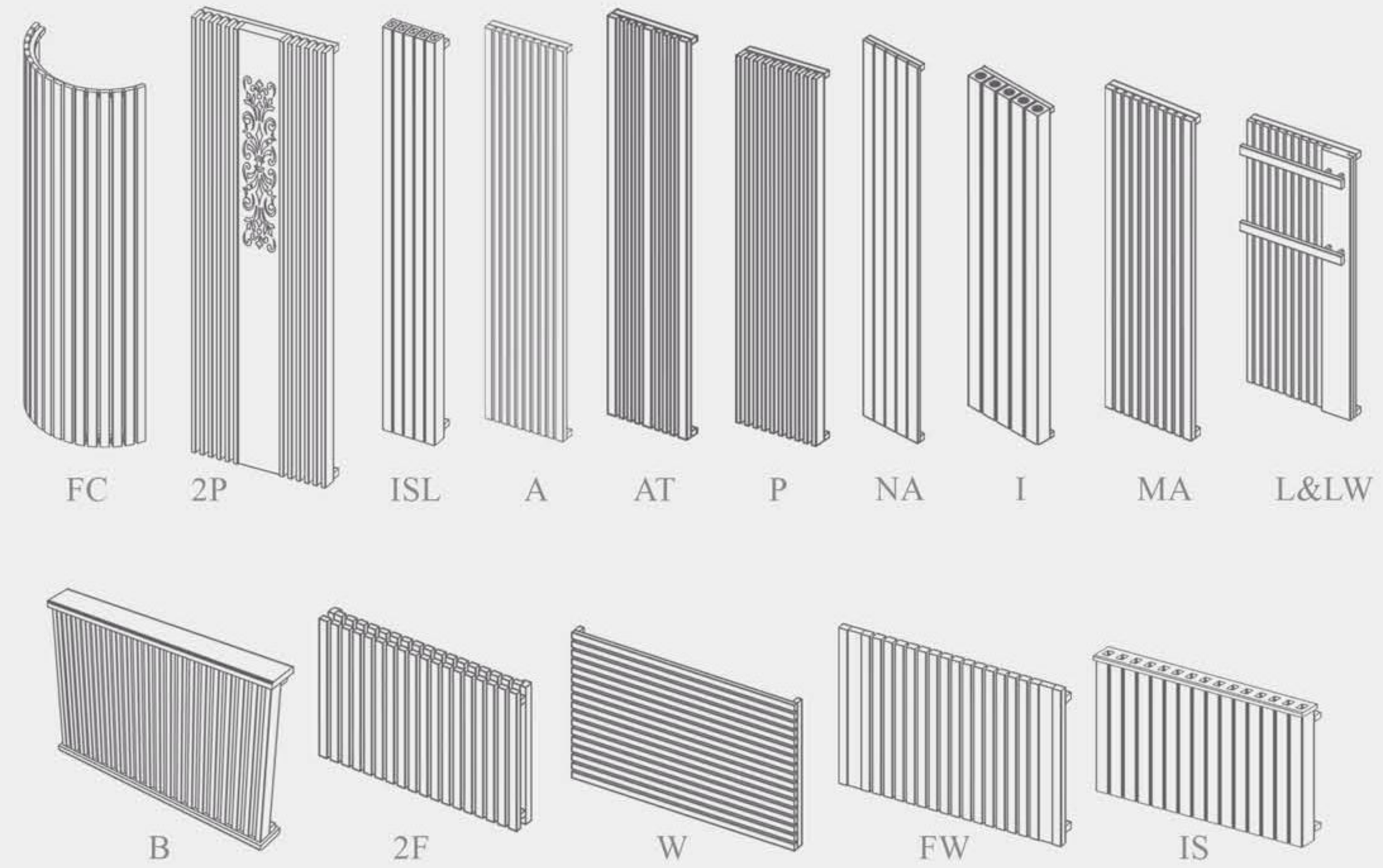

FRAAI
M O O R

Real feeling of Nature

Square Angled
Radiator Valve | Model:
FH 1/2-SR



Twin square radiator valve angled | Model:
FH 1/2-TSR





Detail Of The Installed
Radiator Valve
FH 1/2-SR

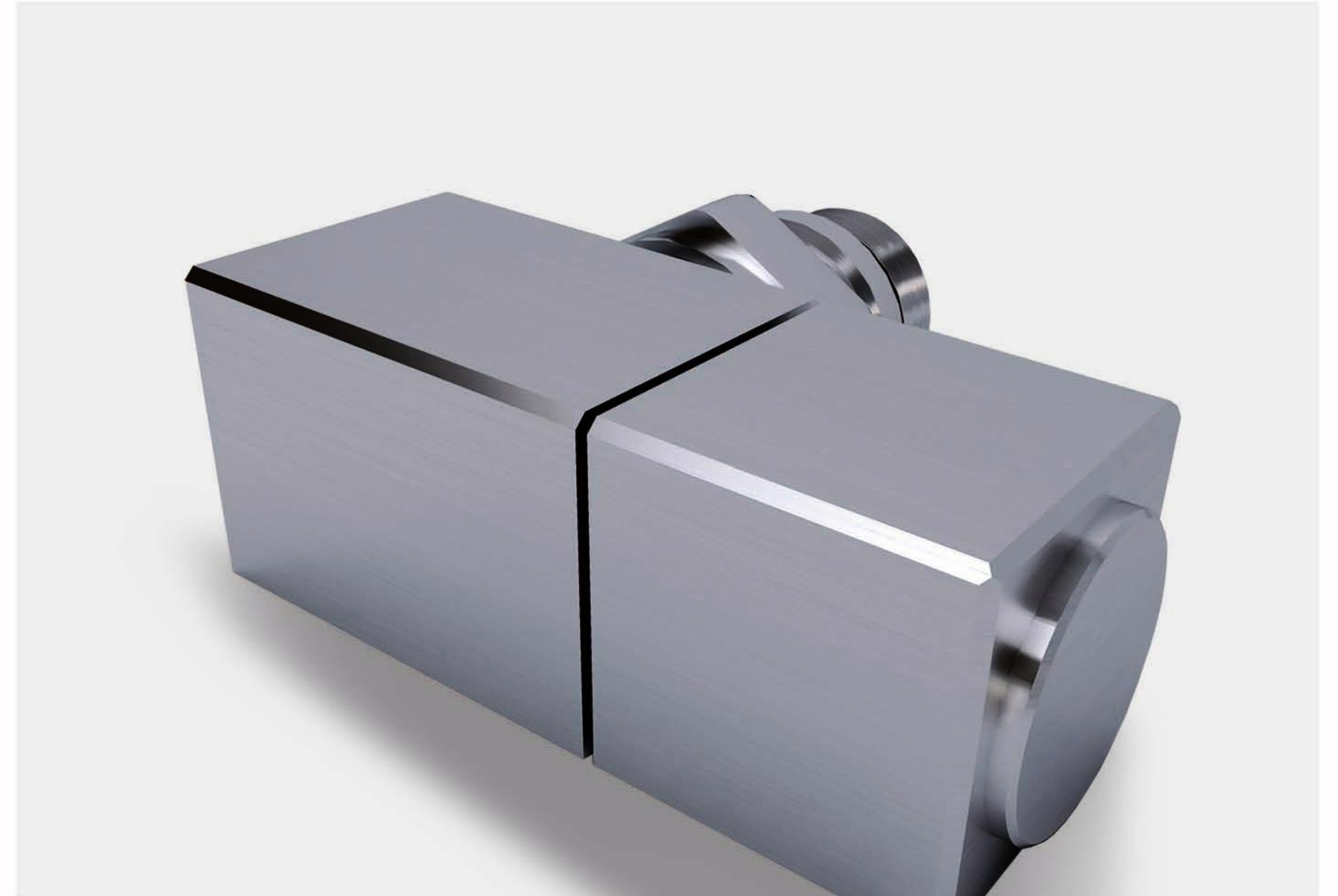

Detail Of The Installed
Radiator Valve
FH 1/2-TSR



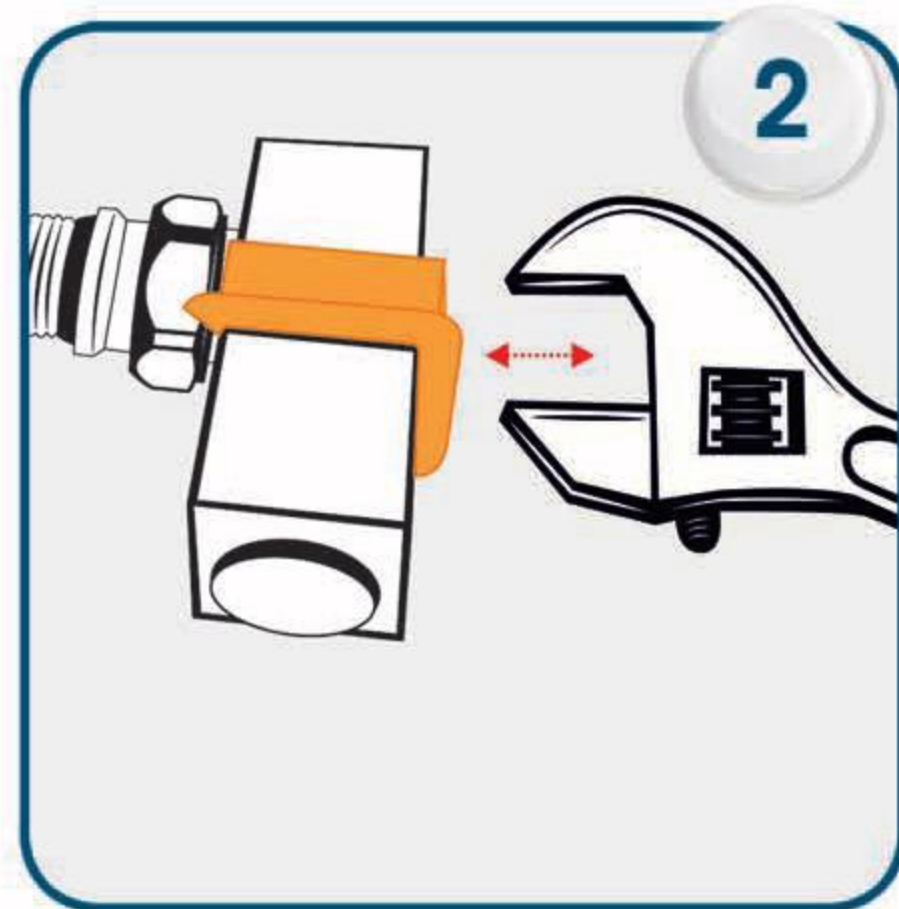
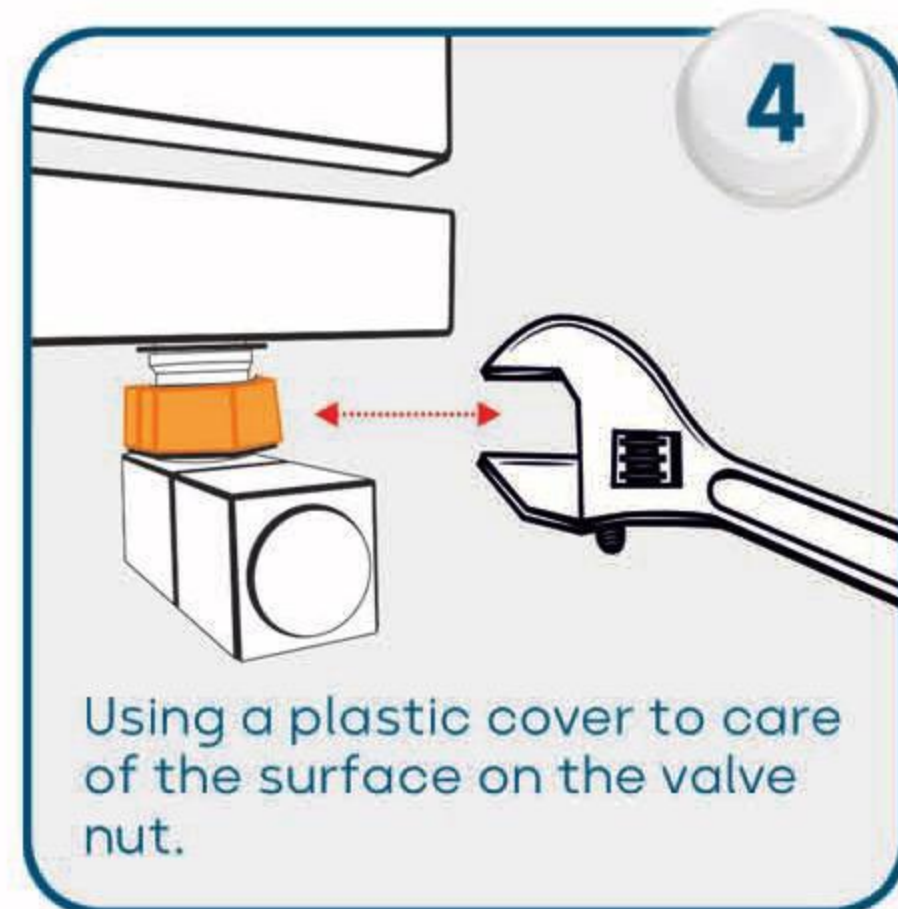
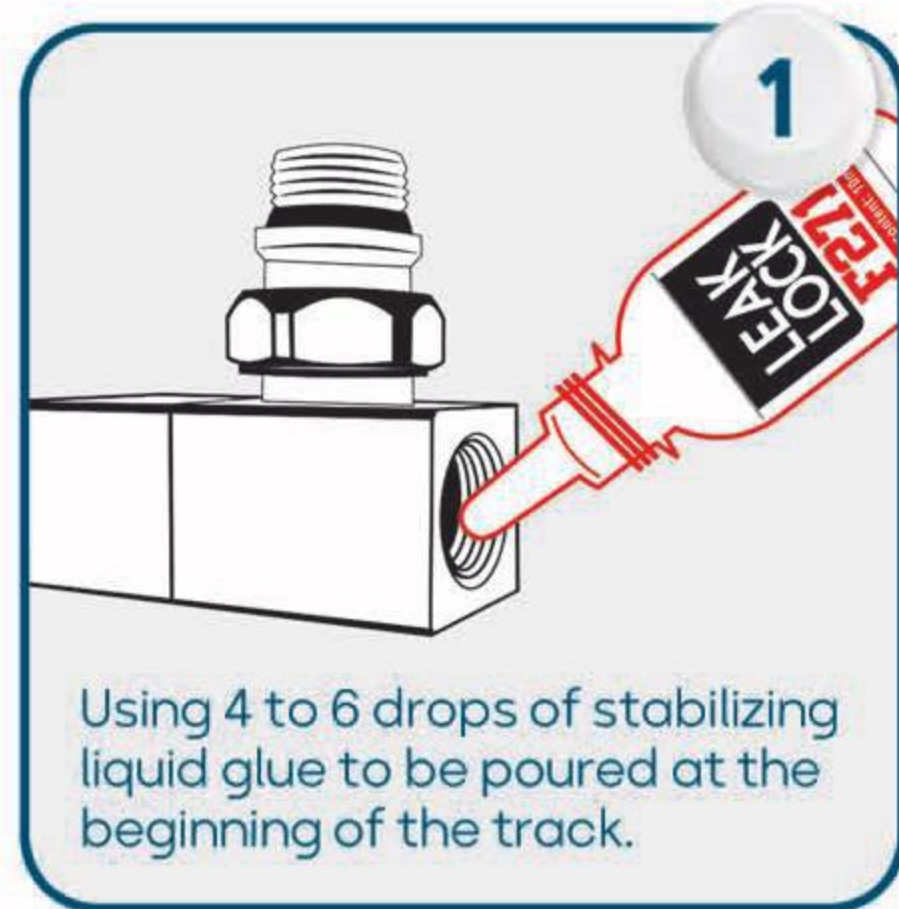
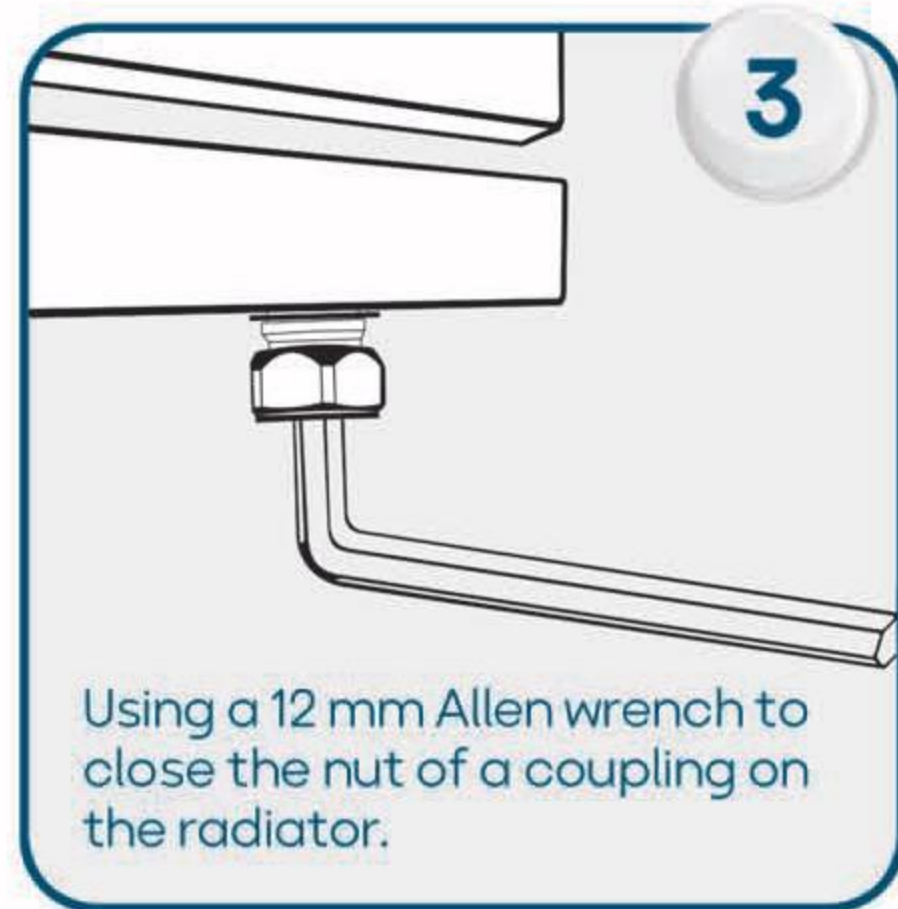

- ✓ **Silicon rubber gaskets**
- ✓ Industrial version
- ✓ Working temp 180-240°C





256 Colors

you can choose

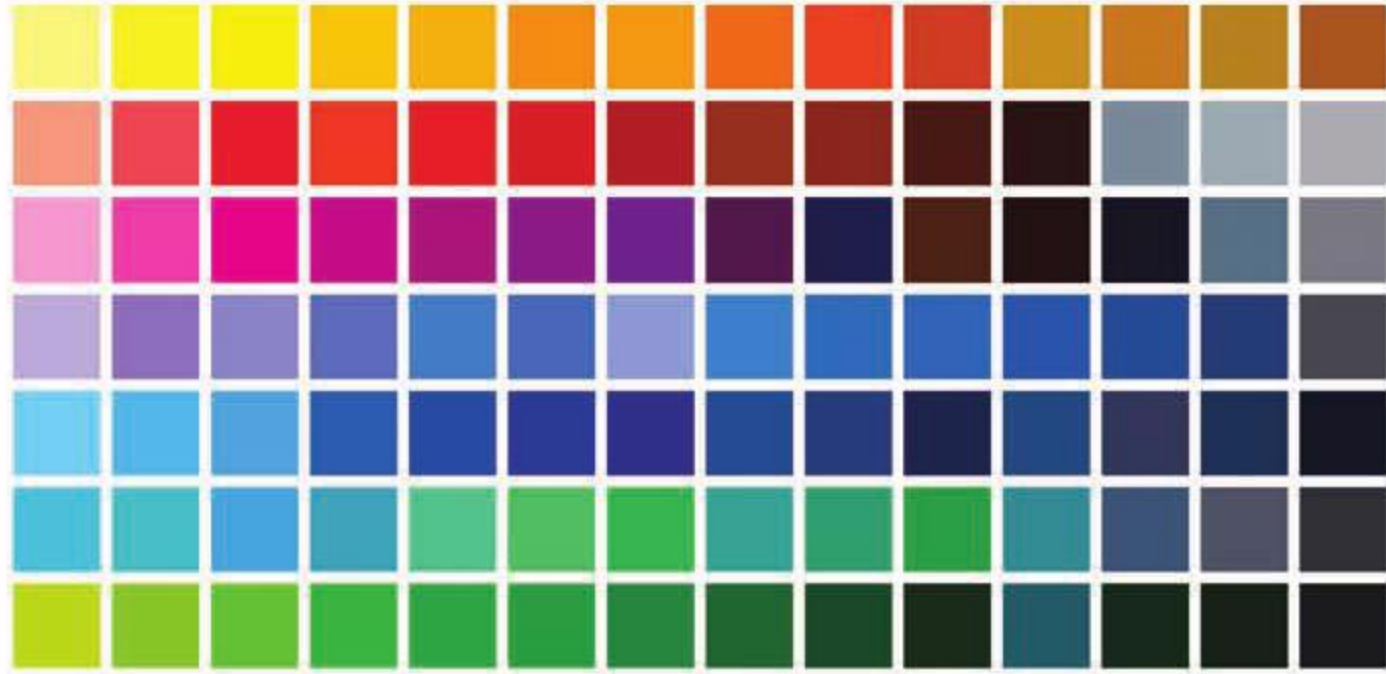



30
YEARS
Guarantee

DIMA

صنعت
کارو

☎ ۰۲۴-۳۳۷۸۴۱۹۰

☎ ۰۹۱۹ ۸۴۲ ۶۷۹۷

📷 KARNOSANAT



@Karnosanat1



www.karnosanat.ir

📍 زنجان، بالاتر از میدان ولیعصر

نیش درب پرسنلی بیمارستان ولیعصر



DIMA Radiator

Made With

The Highest Technology

GRAPHIC DESIGNER:
MAHMOOD KHABIR
+98 917 713 1105
MAHMOODKHABIR.COM